

INSTALLATION AND USER MANUAL



**FILTER UNIT ADAMIK
FT 6xxN A and FT 7xxN A series**

CONTENT

1. IDENTIFICATION DETAILS	4
2. BASIC INFORMATIONS	4
2.1 PURPOSE OF THE MANUAL	4
2.2 USED SYMBOLS	5
2.3 DEFINITION OF OPERATOR QUALIFICATIONS.....	6
3. SAFETY INSTRUCTIONS	7
3.1 RESIDUAL RISKS	7
3.2 GENERAL SAFETY WARNINGS.....	7
3.3 SAFETY PRECAUTIONS FOR HANDLING, ASSEMBLY AND INSTALLATION.....	8
3.4 SAFETY WARNINGS FOR INTENDED USE	9
3.5 SAFETY WARNINGS FOR ADJUSTMENT/MAINTENANCE.....	9
3.6 SAFETY WARNING FOR ENVIRONMENTAL IMPACT.....	9
3.7 SAFETY SIGNS LOCATED ON THE MACHINE.....	9
3.8 RISK OF AN EXTRAORDINARY FORESEEABLE SITUATION	10
4. HANDLING, ASSEMBLY AND INSTALLATION INFORMATIONS	11
4.1 HANDLING, STORAGE AND PACKAGING.....	11
4.2 INSTRUCTIONS FOR MACHINE ASSEMBLY.....	12
4.2.1 Table of handling weights	14
4.3 MACHINE ASSEMBLY	15
4.3.1 Unit assembly.....	16
4.3.2 Filter assembly	26
4.3.3 Waste bags assembly	28
4.4 MACHINE HANDLING.....	28
4.5 INSTALLING THE MACHINE	29
4.5.1 Anchor bolt table	30
4.5.2 Anchor bolt layout on the ground	30
4.6 ELECTRICAL CONNECTION.....	31
4.6.1 Vibration motor connection.....	31
4.7 INSTALLATION OF OPTIONAL ACCESSORIES	32
4.7.1 Installation of fairing panels (covered units FT 7xxN A)	32
4.7.2 Fan installation (if equipped)	36
4.7.3 Electrical switchboard (if equipped).....	38
4.8 TEST INSPECTION.....	39
5. TECHNICAL INFORMATIONS	40
5.1 MANUFACTURER AND MACHINE IDENTIFICATION	40
5.2 MACHINE DESCRIPTION.....	40
5.3 OPERATION CYCLE DESCRIPTION	41
5.4 TECHNICAL DATA.....	42

5.4.1 Dimensions and weight of the unit	42
5.4.2 Fan parameters.....	43
5.4.3 Air inlet dimensions	44
5.4.4 Clean air outlet dimensions.....	44
5.4.5 Sleeve filter cleaning system (vibrating motor cleaning)	45
5.4.6 Noise.....	45
5.4.7 Diagram and electrical values	45
5.4.8 Filter and waste bag parameters.....	46
5.5 SAFETY DEVICE DESCRIPTION.....	46
5.6 DESCRIPTION OF PERIMETER AREAS	46
6. INFORMATION FOR USE	48
6.1 RECOMMENDATIONS FOR USE	48
6.2 CORRECT USE / IMPROPER USE	48
6.2.1 Type of extracted material	48
6.3 IN CASE OF FIRE	49
7. ADJUSTMENT INFORMATION	49
7.1 RECOMMENDATIONS FOR ADJUSTMENT	49
7.1.1 Air flow regulation	49
7.1.2 Vibration motor adjustment	50
8. MAINTENANCE	50
8.1 MAINTENANCE RECOMMENDATIONS	50
8.2 EMPTYING THE WASTE BAGS	52
8.3 CLEANING THE FILTERS	52
8.4 TABLE OF SCHEDULED MAINTENANCE INTERVALS	52
8.5 CLEANING AND DISPOSAL.....	53
9. TROUBLESHOOTING	54
10. INFORMATION ON PARTS REPLACEMENT	55
10.1 ORDERING SPARE PARTS AND ACCESSORIES.....	55
10.2 RECOMMENDATIONS FOR REPLACEMENT OF SPARE PARTS	55
10.3 LIST OF REPLACEABLE PARTS	56
10.3.1 Removing filters	57
10.3.2 Removing waste bags.....	58
10.4 OPTIONAL EQUIPMENT	59
10.5 DECOMMISSIONING.....	59
11. WARRANTY	61
11.1 RESPONSIBILITY FOR DEFECTS.....	61
11.2 VOLUNTARY ADDITIONAL WARRANTY.....	61
11.3 EXCLUSIONS FROM RESPONSIBILITY FOR DEFECTS AND WARRANTY	61
12. TERMS OF SERVICE.....	62

1. IDENTIFICATION DETAILS

Name and address of manufacturer / supplier:



ADAMIK Company, s.r.o.
Mitrovická 804
739 21 Paskov
Czech Republic
VAT EU: CZ26845318

2. BASIC INFORMATIONS

2.1 PURPOSE OF THE MANUAL

The purpose of this manual is to provide, in part, the machine operator, operator and maintenance technician with guidance on the use, prevention and reduction of human-machine interaction risks.

Person	Chapters in the manual they must familiarize themselves with
The person installing the unit	<ul style="list-style-type: none">- Basic information- Safety instructions- Handling, assembly and installation informations- Technical informations- Information on parts replacement
Operator	<ul style="list-style-type: none">- Basic information- Safety instructions- Information for use
Maintenance technician	<ul style="list-style-type: none">- Basic information- Safety instructions- Handling, assembly and installation informations- Information for use- Adjustment information- Maintenance- Troubleshooting- Information on parts replacement



The responsible person must keep the documentation in a suitable place so that it is always available for consultation in a legible and clear state. In case of loss or wear, request replacement documentation directly from ADAMIK Company.

Specific topics of interest are easy to find in the table of contents.

Some information may not fully correspond to the actual configuration of the delivered machine.







Any additional information that may be inserted will not affect readability or compromise the level of security.







The manufacturer reserves the right to change the data without being obliged to notify in advance, as long as these changes do not change the level of safety.

Any feedback from operators can be an important contribution to improving the after-sales services that the manufacturer offers to its customers.

Some symbols, the meaning of which is described below, are used to highlight some text or to indicate significantly important specifications.

2.2 USED SYMBOLS

Symbol	Description
	Danger – Warning The symbol indicates situations of serious danger which, if neglected, may seriously endanger the health and safety of persons.
	Danger – Warning The symbol indicates situations of serious danger which, if neglected, may seriously endanger the health and safety of persons.
	Danger – Warning This symbol applies exclusively to equipment compliant with the ATEX Directive 2014/34/EU. Operations marked with the following symbol must only be performed by a qualified person with special training for safe work in areas with potentially explosive atmospheres.
	Danger of explosion This symbol indicates situations of serious danger which, if neglected, can cause an explosion and seriously endanger the health and safety of people.
	Caution – Warning The symbol indicates the need to adopt reasonable behavior in order not to endanger the health and safety of people and avoid economic damage.
	Important The symbol indicates very important technical and operational information that must not be neglected.
	Use protective gloves.

Symbol	Description
	Wear safety shoes.
	Use a protective face mask.
	Use hearing protection.
	Use safety glasses.
	Use a safety helmet.
	For operations at a certain height, use a work-at-height harness.

2.3 DEFINITION OF OPERATOR QUALIFICATIONS

Some terms that are frequently used in the manual are described in order to clearly define their meaning.

Operator qualification	Description
Qualified personnel	Employees who have completed specialization, education and training courses and have experience in installation, commissioning and maintenance of equipment
Experienced maintenance technician	A technician selected and authorized from among those who have the qualifications, skills and information to perform routine and emergency maintenance interventions.

3. SAFETY INSTRUCTIONS



The device is intended for extracting chips and sawdust from woodworking machines. It must not be used for easily flammable and explosive materials. It is not recommended for extracting abrasive materials (e.g. metals). Pieces of wood (knots, etc.) must not be extracted, which may cause breakage or deformation of the impeller. The device is suitable for environments without the risk of fire.



Carefully read the instructions in this manual and the instructions specific to the machine and on the machine.

3.1 RESIDUAL RISKS

Residual risk	Description
Voltage hazard	Maintenance work carried out on the electrical parts of the machine carries with it the risk of electric shock.
Dust inhalation hazard	Maintenance activities carried out inside the machine involve the risk of inhaling potentially carcinogenic dust.
Fire hazard	Routine operations performed in spite of the prohibition described in the "Correct use/ Improper use" chapter. Maintenance operations performed despite the prohibition described in section "8.1 Maintenance recommendations".
Explosion hazard	Maintenance operations carried out despite the prohibition expressed in section "6.2 Correct use / Improper use". Maintenance operations carried out despite the prohibition expressed in section "8.1 Maintenance recommendations".
Cutting hazard	Maintenance operations carried out without the use of protective gloves to remove moving sheet metal parts carry the risk of cutting fingers.

3.2 GENERAL SAFETY WARNINGS

Personnel carrying out any type of intervention throughout the life of the machine must have precise technical skills, special abilities resulting from acquired and recognized experience in the sector, must be trained in the use of the necessary work tools and appropriate personal protective equipment with reference to the laws in force and in force at the location machine use.

Failure to comply with these requirements may cause harm to people's health and safety.

Use the personal protective equipment specified in the instructions.



The machine contains potentially explosive dust deposits and/or gases, therefore it is forbidden to approach or introduce any possible source of ignition into the machine:

- **Open flame**
- **Hot surfaces**
- **Sparks**
- **Gas**
- **Electrical parts under voltage**
- **Electrostatic charge**

3.3 SAFETY PRECAUTIONS FOR HANDLING, ASSEMBLY AND INSTALLATION

Use suitable lifting equipment for handling and take all safety precautions for the activities carried out in the workplace.

Before moving the machine, disconnect it from the electrical supply and the piping system.



Electrostatic charge built up in flexible pipes could ignite a fire. Therefore, they must have electrical conductivity and be grounded.



The machine must be installed in an area where there is no explosion hazard.

The maximum permissible tightening values, when exceeded, the screws lose their mechanical resistance, are listed in the tables.

Tightening torques must be applied slowly and continuously using a torque wrench. The stated values must be reduced by 10 % when shock absorbers are used.

The table applies to screws of class 4.8:

Diameter per pitch	Screw section (mm ²)	Screw tightening torque (Nm)
6 x 1	20	3,5
8 x 1,25	36	8
10 x 1,5	58	17
12 x 1,75	84	28

The table applies to screws of class 8.8:

Diameter per pitch	Screw section (mm ²)	Screw tightening torque (Nm)
6 x 1	20	10,4
8 x 1,25	36	25
10 x 1,5	58	50
12 x 1,75	84	87

3.4 SAFETY WARNINGS FOR INTENDED USE

The machine was designed to work within the limits prescribed and indicated in the manual.

The machine is designed for operation in an environment protected from atmospheric weather.

Using the machine to achieve production levels other than those described in this manual will be considered "IMPROPER USE".

Carefully read the instructions in the section "6. Information for use".

To be prepared for emergency situations, carefully read the instructions in section "6.3 In case of fire".

3.5 SAFETY WARNINGS FOR ADJUSTMENT/MAINTENANCE

Perform routine maintenance as described in this manual.

Before any maintenance, disconnect the machine from all power sources.



Potentially explosive atmospheres may occur during adjustment and maintenance, therefore it is prohibited to approach or introduce any possible source of ignition into the machine:

- ***Open flame***
- ***Hot surfaces***
- ***Sparks***
- ***Gas***
- ***Electrical parts under voltage***
- ***Electrostatic charge***

3.6 SAFETY WARNING FOR ENVIRONMENTAL IMPACT

Before using the machine, the operator must be provided with information, instructions and training on the substances for which the machine is to be used, including how to safely remove and dispose of accumulated pollutants.







Do not disperse polluting material into the environment. Dispose in accordance with applicable laws.

Improper cleaning or insufficient replacement of filters can cause the dispersion of pollutants in the external environment.

3.7 SAFETY SIGNS LOCATED ON THE MACHINE

The following warning labels must be placed on the machine. see the summary diagram included in this section.

Some tags may not be present if they refer to optional components that are not installed.

Symbol	Description
	Grounding
	Danger of limbs, hair and loose clothing being drawn into the entrance openings of the device.
	Keep limbs, hair, and loose clothing away from the inlet openings. They can be pulled into the inlet openings of the device, which could cause injury.
	Warning.
	Direction of rotor rotation.
	DANGER! Risk of serious cuts. Before removing shutters and hoses, unplug the extraction unit from the power source and wait 5 minutes for the internal rotating parts to stop.
	CAUTION! To reduce the risk of injury from moving parts, keep hands and fingers away from inlet openings. Operate the unit only with inlet openings covered with covers or connected to a flexible hose. The impeller continues to rotate for 5 minutes after the extraction unit is turned off. Before servicing or cleaning dusty materials, make sure the extraction unit is turned off, disconnected from the power source, and that the impeller has stopped rotating.
	WARNING! This appliance contains dust hazardous to health. Bag and filter emptying and maintenance operations, including the removal of dust collection components, must only be carried out by authorised personnel wearing appropriate personal protection. Do not operate the extraction unit without the filter system fully installed.

3.8 RISK OF AN EXTRAORDINARY FORESEEABLE SITUATION

If an object gets caught in the impeller (long wet chips, rags, paper) it will cause sudden vibrations. The extraction device must be switched off, wait until the impeller stops, and unplug the power cord from the electrical outlet. Then the pipes (hoses, pipe elements) must be dismantled, the impeller cleaned and reassembled.

Qualified personnel must carry out a technical inspection at least once a year, which consists of, for example, checking the filter for damage, checking the air tightness of the machine and the pipe system and the correct functioning of the control and regulation mechanism.

4. HANDLING, ASSEMBLY AND INSTALLATION INFORMATIONS

4.1 HANDLING, STORAGE AND PACKAGING



The standard packaging of the machine does not guarantee protection against rain. The machine must be stored in a closed environment with a relative humidity lower than 70%.



The machine must be stored at temperatures between -10 °C and +40 °C inclusive.



Use appropriate lifting equipment when handling materials and observe all safety precautions required for workplace activities. Dispose of the packaging material in accordance with applicable legislation.



The machine is delivered in a disassembled state, most often in a wooden crate.

Delivery in wooden crate:

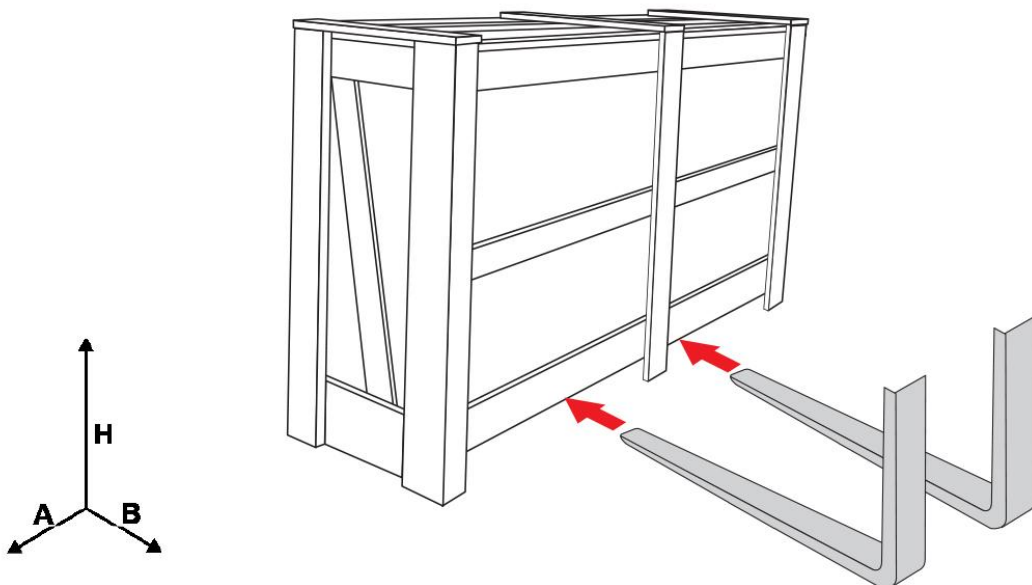

Provide a defined and adequate area with a level floor or surface for unloading and storing packages.

It is always advisable to keep the packaging in a horizontal position during handling to prevent loss of stability and/or tipping over.

4.2 INSTRUCTIONS FOR MACHINE ASSEMBLY



The machine needs to be assembled.



The machine must be installed in a fixed position. The machinery must be mounted in the location specified by the operator's project.



Before starting the installation, the thickness of the cement floor slab and the reinforcement must be dimensioned depending on the geological characteristics of the terrain and/or the structure of the building. See sections "5.4 Technical data" and "5.6 Description of perimeter areas".



The machine must be installed on a flat surface and fixed to the ground with dowels and/or chemical bolts (from 12 mm).



The simultaneous presence of two qualified persons is necessary to assemble the machine. They must complete specialization and training courses and must have experience installing, activating and performing system maintenance.



The machine must not be assembled by persons under the influence of alcohol, drugs or any other intoxicating substances. Otherwise, there is a risk of injury or death.



Before starting the assembly, it is necessary to familiarize yourself with the instructions for assembly and use of the device. The individual assembly steps must be carried out exactly in the order given in this manual.



Before assembly, visually inspect the material to ensure that it has not been damaged in transit. If it shows signs of damage, please notify the seller within 2 days of delivery.



Before proceeding with the assembly, read the paragraph "4.5 Installing the machine".



During assembly, use the personal protective equipment specified in the manual.



For transport reasons and/or on the basis of special agreements between the customer and the supplier, the parts required to assemble the machine may differ from the parts described in the assembly description.



Before opening the package, tilt the box just enough to prevent the material from tipping over. Do not exceed the maximum angle shown in the figure below.

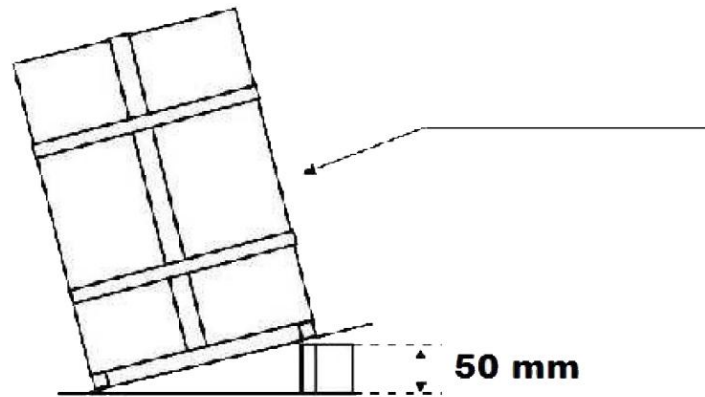

Before assembly, it is necessary to know the weight of the components. See table.



When assembling the machine, use the eyebolts supplied by the supplier to lift the panels.



Use suitable lifting equipment for handling. Take all the safety precautions prescribed for the activities carried out in the workplace.



When handling components, proceed as follows:

- ***Find lifting points as shown in the assembly steps and use slings and hooks.***
- ***Prepare for lifting with a crane (gantry crane or forklift).***
- ***Perform the first, very slow lifting maneuver, keeping the part as close to the ground as possible to balance the load.***



Electrostatic charge accumulated in flexible pipes could cause a fire. Therefore, they must be electrically conductive and earthed.



The extraction unit must be installed in a non-explosive environment.



The extraction unit is designed for operation in an environment protected from atmospheric weather.



For information on the correct installation of the machine and the correct dimensioning of the piping system, please contact the technical department of ADAMIK Company in advance.

The maximum permissible tightening values, when exceeded, the screws lose their mechanical resistance, are listed in the tables.

Tightening torques must be applied slowly and continuously using a torque wrench. The stated values must be reduced by 10 % when impact drivers are used.

The table applies to screws of class 4.8:



Diameter per pitch	Screw section (mm ²)	Screw tightening torque (Nm)
6 x 1	20	3,5
8 x 1,25	36	8
10 x 1,5	58	17
12 x 1,75	84	28

The table applies to screws of class 8.8:

Diameter per pitch	Screw section (mm ²)	Screw tightening torque (Nm)
6 x 1	20	10,4
8 x 1,25	36	25
10 x 1,5	58	50
12 x 1,75	84	87

4.2.1 Table of handling weights

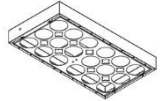
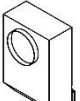

Open units:

	Base 	Legs 	Side panels 	Roof group 	Deflector 
FT 616N A	34 kg	2 x 15 kg	2 x 16 kg	34 kg + VM*	25 kg
FT 627N A	52 kg	2 x 15 kg	2 x 16 kg	49 kg + VM	25 kg
FT 638N A	72 kg	2 x 15 kg	2 x 16 kg	69 kg + 2x VM	25 kg
FT 625N A	34 kg	2 x 15 kg	2 x 22 kg	34 kg + VM	25 kg
FT 637N A	52 kg	2 x 15 kg	2 x 22 kg	49 kg + VM	25 kg
FT 650N A	72 kg	2 x 15 kg	2 x 22 kg	69 kg + 2x VM	25 kg
FT 631N A	34 kg	2 x 15 kg	2 x 28 kg	34 kg + VM	25 kg
FT 647N A	52 kg	2 x 15 kg	2 x 28 kg	49 kg + VM	25 kg
FT 662N A	72 kg	2 x 15 kg	2 x 28 kg	69 kg + 2x VM	25 kg

*VM ... vibrating motor

Weight of the assembly for connection with the fan ... 9 kg.

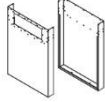
Covered units:

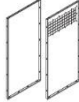
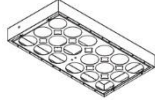
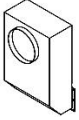
	Base	Legs	Side panels	Fairing panels	Roof group	Deflector
						
FT 716N A	34 kg	2 x 15 kg	2 x 16 kg	4 x 12 kg	34 kg + VM*	25 kg
FT 727N A	52 kg	2 x 15 kg	2 x 16 kg	6 x 12 kg	49 kg + VM	25 kg
FT 738N A	72 kg	2 x 15 kg	2 x 16 kg	8 x 12 kg	69 kg + 2x VM	25 kg
FT 725N A	34 kg	2 x 15 kg	2 x 22 kg	4 x 15 kg	34 kg + VM	25 kg
FT 737N A	52 kg	2 x 15 kg	2 x 22 kg	6 x 15 kg	49 kg + VM	25 kg
FT 750N A	72 kg	2 x 15 kg	2 x 22 kg	8 x 15 kg	69 kg + 2x VM	25 kg
FT 731N A	34 kg	2 x 15 kg	2 x 28 kg	4 x 19 kg	34 kg + VM	25 kg
FT 747N A	52 kg	2 x 15 kg	2 x 28 kg	6 x 19 kg	49 kg + VM	25 kg
FT 762N A	72 kg	2 x 15 kg	2 x 28 kg	8 x 19 kg	69 kg + 2x VM	25 kg

*VM ... vibrating motor

Weight of the assembly for connection with the fan ... 9 kg.

4.3 MACHINE ASSEMBLY



Use personal protective equipment during assembly.



The machine is installed in a fixed position and connected to the utility networks by means of a fan and rigid galvanized steel pipes. The machine must be mounted in the location specified by the operator's project.



See table "4.2.1. Table of handling weights".

Equalization of potentials

The conductive parts of the extraction device must be connected to each other and to the protective conductor of the power supply. Care must be taken to ensure that additional conductors provided by the manufacturer are not removed or damaged.

It is recommended that the machine be installed close to utility networks and connected to the extracted machine using rigid pipes or hoses.



To dissipate electrostatic charges, the extraction device must be grounded (either by connection to the protective connection or to the grounding itself) by a person with appropriate electrical qualifications.



The room in which the extraction device with return air exhaust is located must be sufficiently ventilated. The ventilation must comply with the relevant national standards.

4.3.1 Unit assembly

1) Place leg panel in the location designated for the machine..

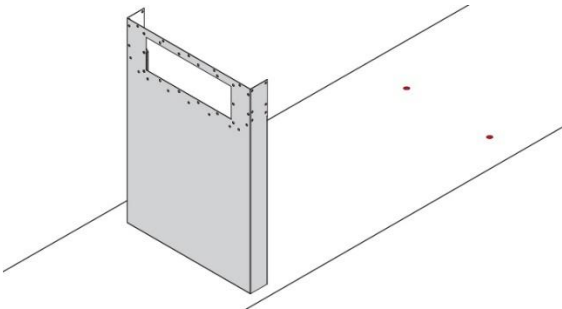

2)



Turn the base over using suitable lifting equipment and the intervention of at least two people.

If necessary, assemble the parts together and seal.

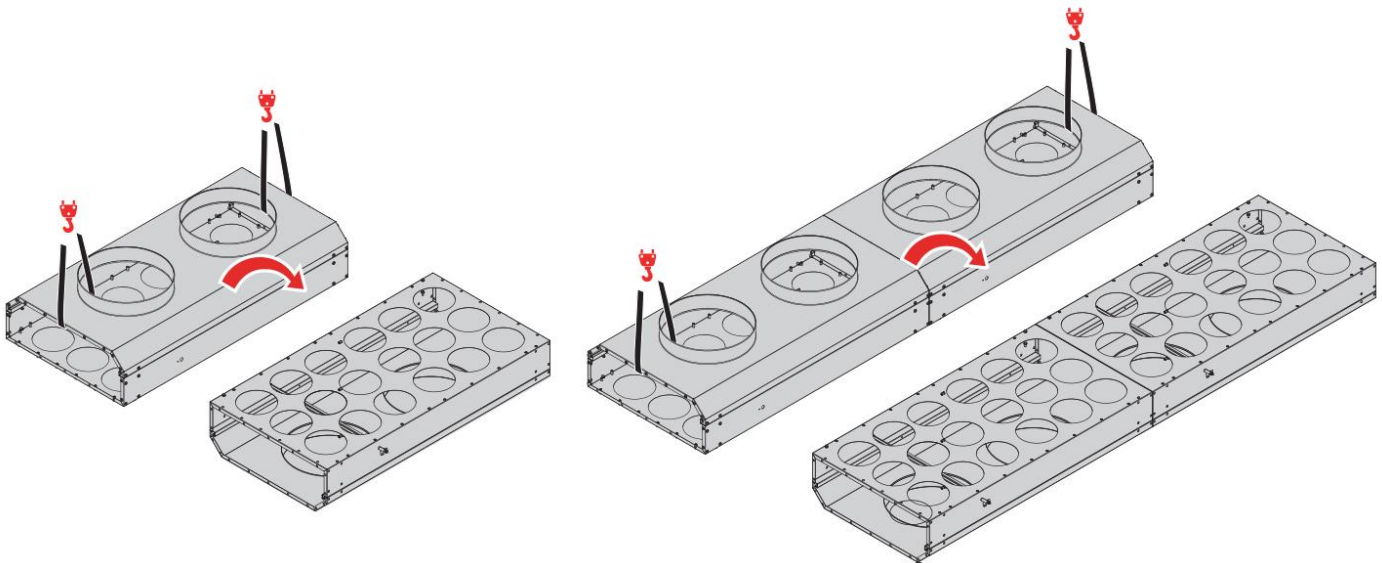

3)



Lift the base using a suitable lifting equipment.

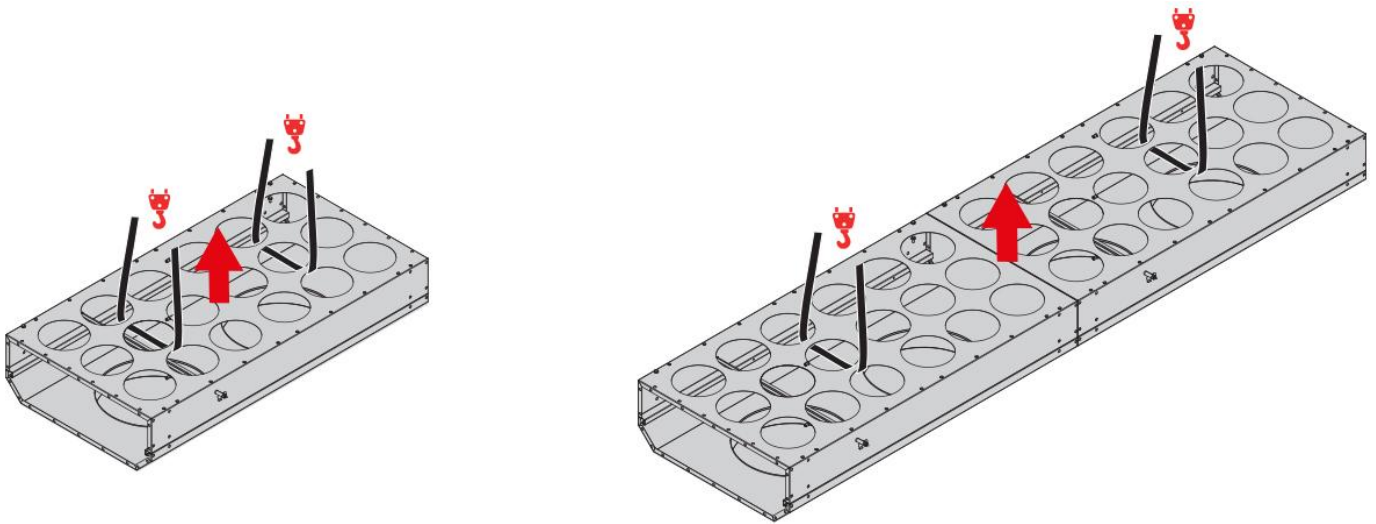

4) Apply sealant between the leg and the base.

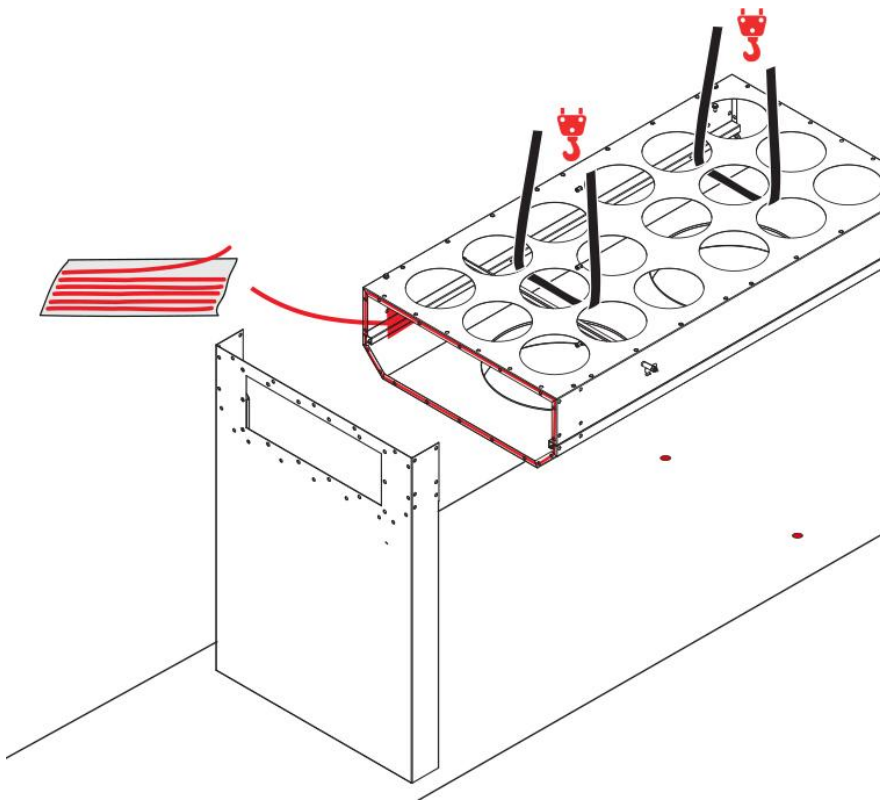

5) Fix the leg with ØM8x16 TBEI screws. Tighten all screws.

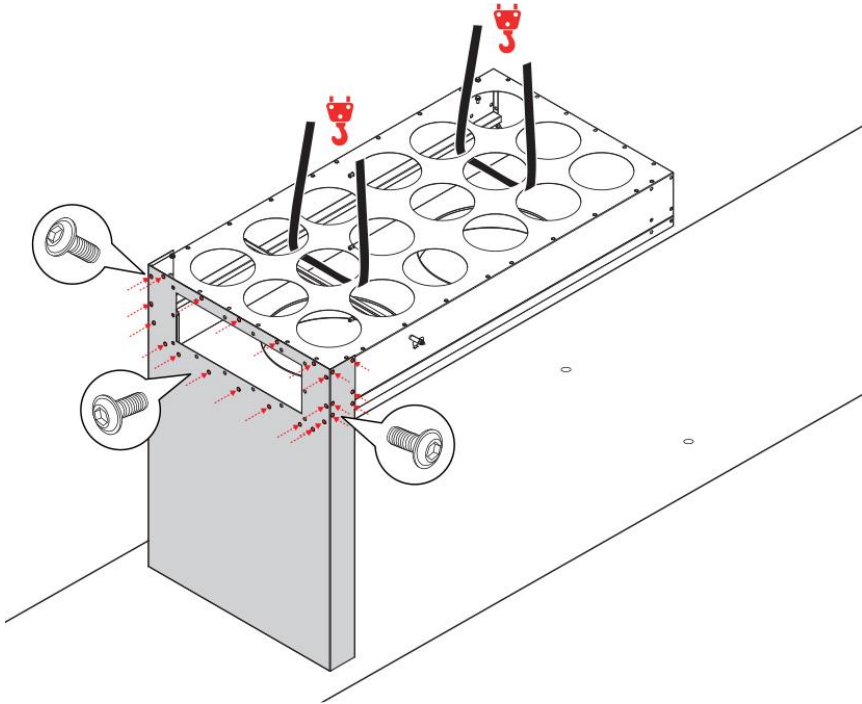

6) Proceed in the same way when assembling the other leg.

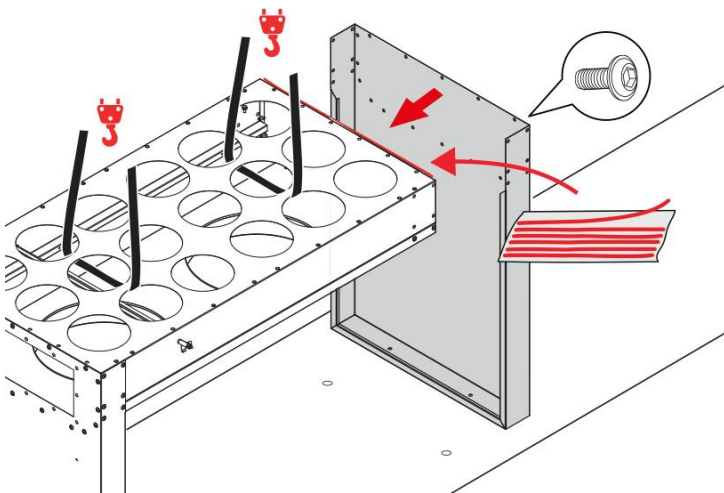

7) Tighten all screws.

8)



Assemble the eye bolts to lift the side panel.

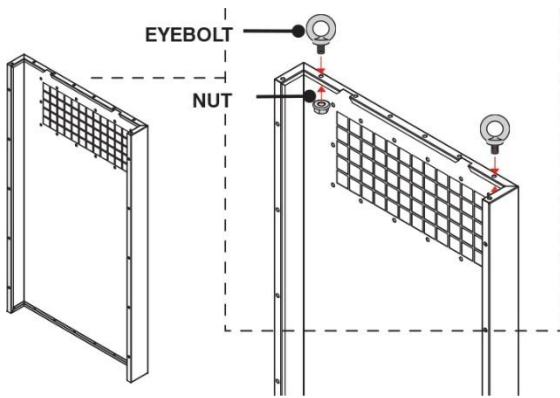

9) Lift the side panel.

10) Match the holes.

11) Fix the screws with washers ØM8x16 .
Tighten all screws

12) Remove eye bolts.

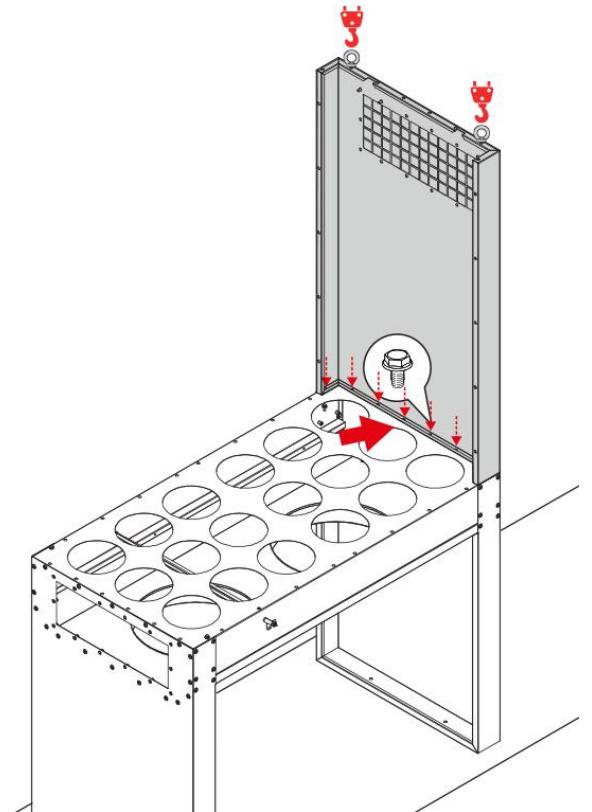

13) Assemble the second panel in the same way.

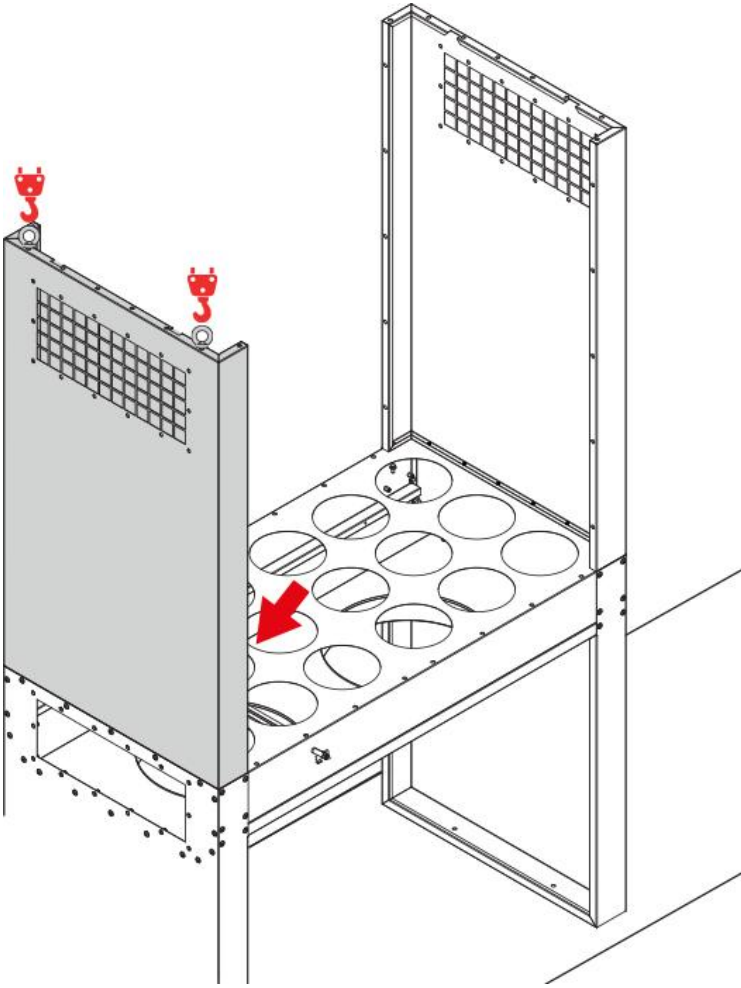

14)



Overturn the roof panel using suitable lifting equipment and with the intervention of at least two people.

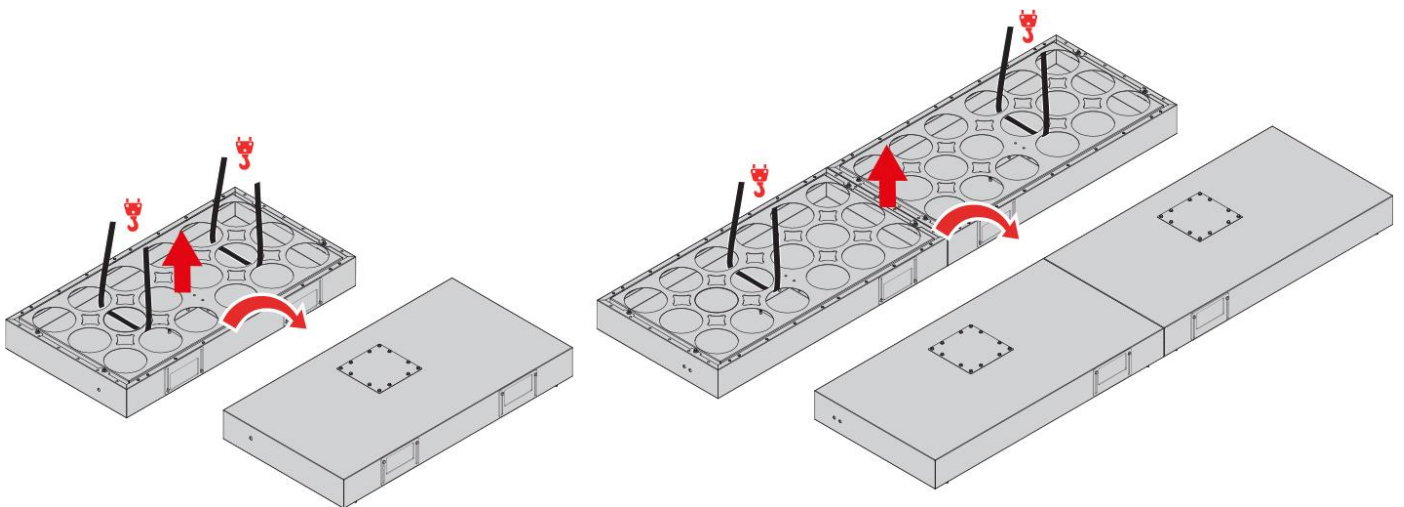

- 15) Unscrew the vibration motor inspection panel.
(For FT 638N, FT 650N, FT 662N, FT 738N, FT 750N and FT 762N units, two inspection panels for two vibration motors.)

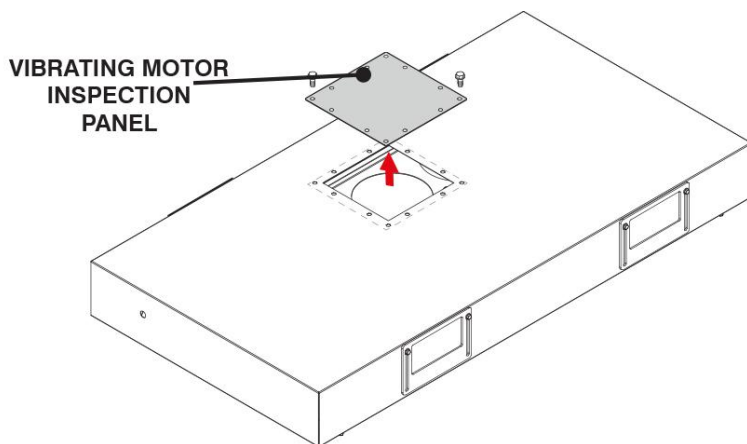

16)



RAISE THE SLIDING LIFTING PLATES TO HANDLE THE ROOF PANEL.

1. Loosen the screws.
2. Raise the sliding lifting plates.
3. Tighten the screws.
4. **Tighten all screws.**

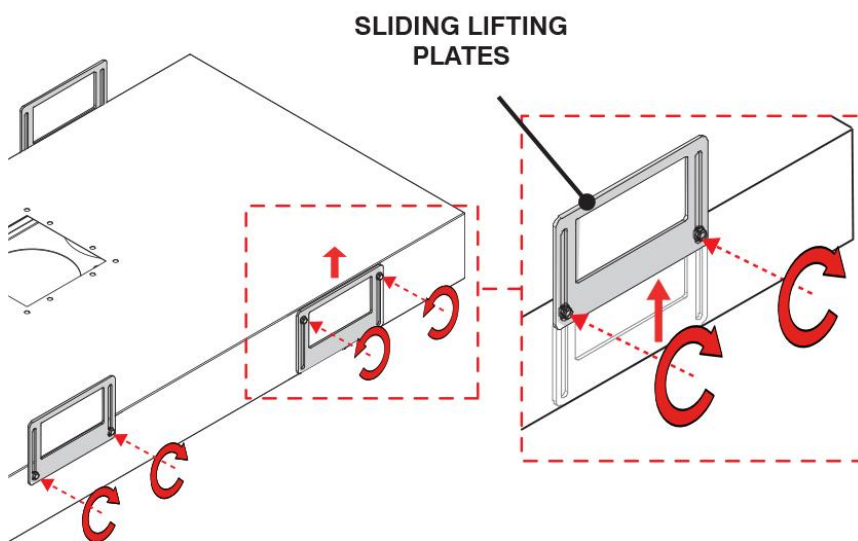

**The lifting plates are only used to handle the roof panel.
DO NOT USE lifting plates to handle the machine.**

- 17) Lift the roof and mount the vibration motor.
(For units FT 638N, FT 650N, FT 662N, FT 738N, FT 750N and FT 762N two vibration motors.)

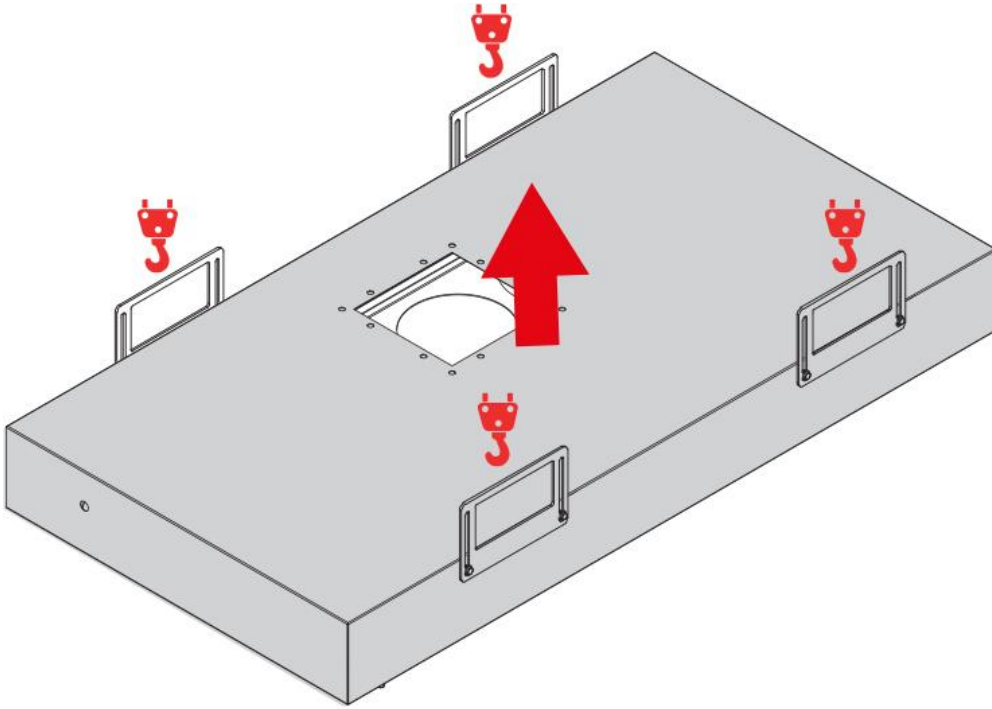

- 18) Place the vibration motor on the tube plate. Match the two holes.

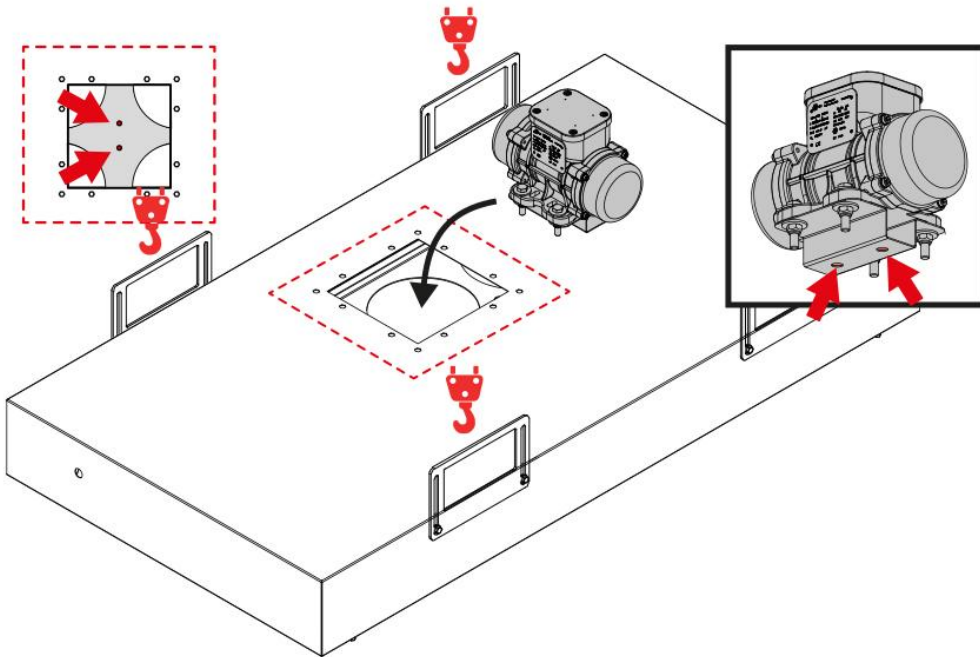

19) Fix the vibration motor with ØM8x16 washer screws.

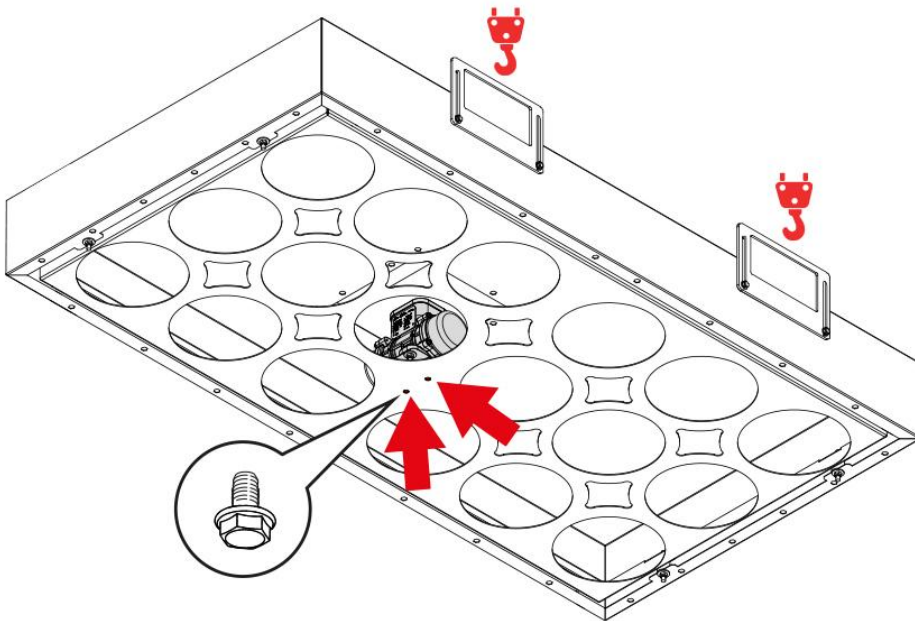

20) Screw in the cable gland.
(For units FT 638N, FT 650N, FT 662N, FT 738N, FT 750N and FT 762N two cable glands.)

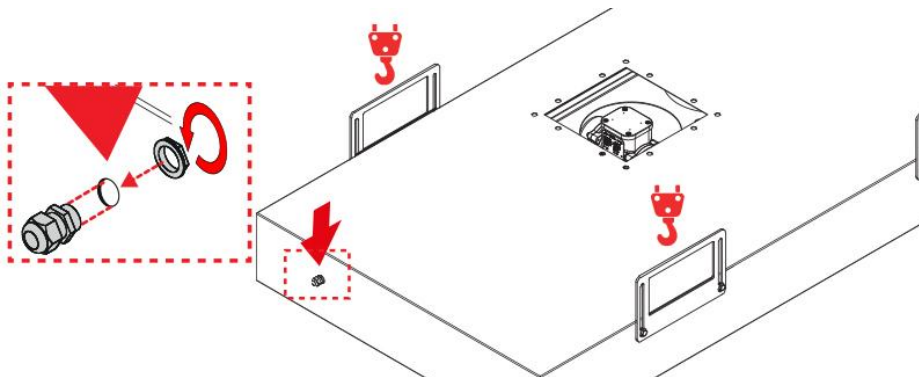

21) Pass the vibration motor cable through the cable gland.

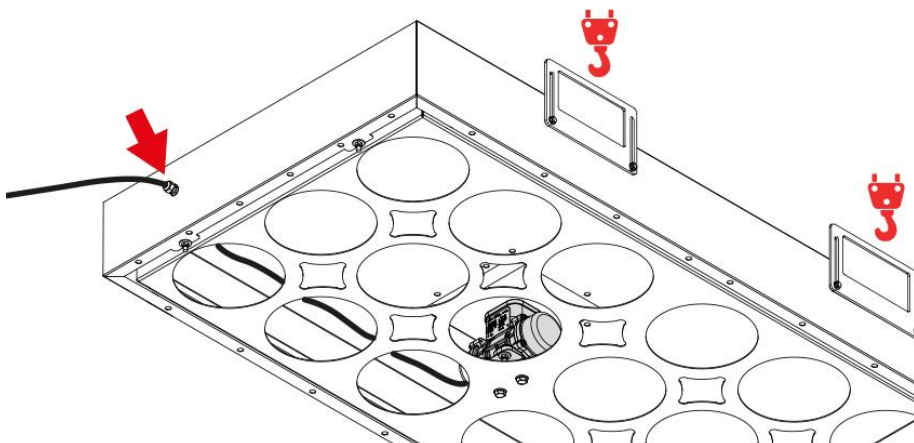



Electrical connection of the vibration motor see paragraph "4.6.2 Electrical connection".

22) Screw on the vibration motor inspection panel.

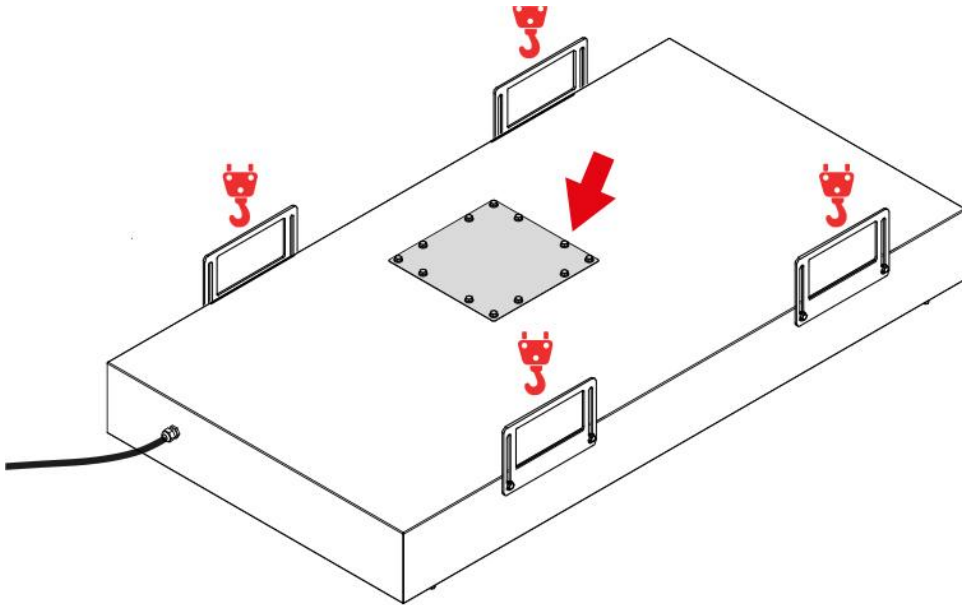

23) Lift the roof panel.

24) Match all the holes.

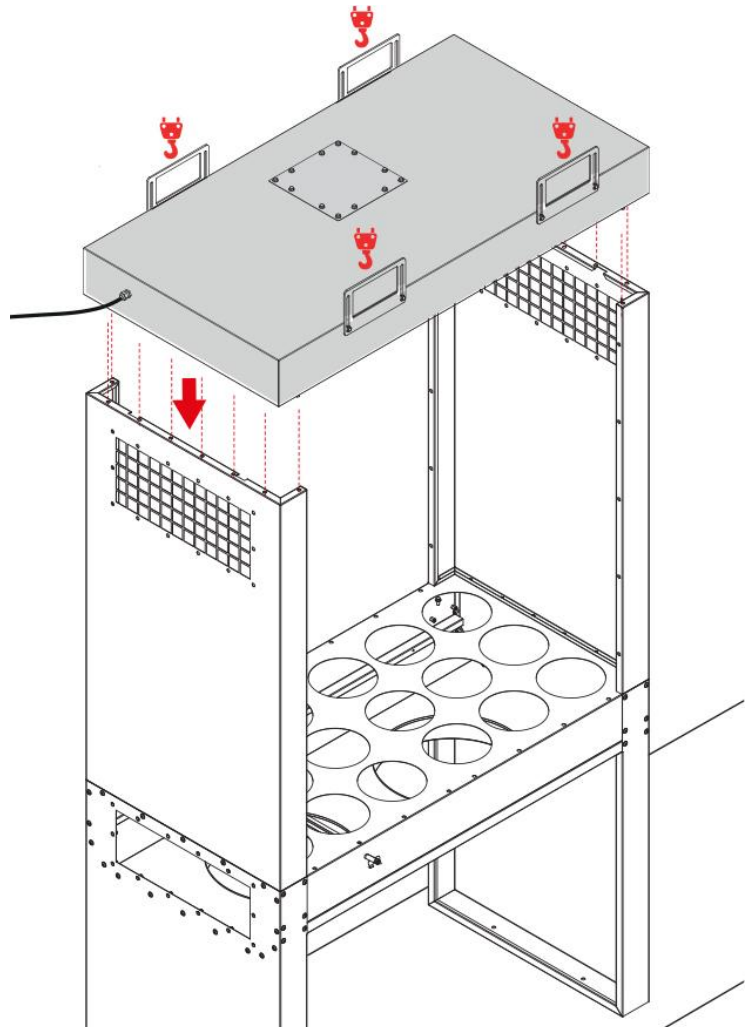

25) Fix with washered screws ØM8x16 .

26) Tighten all screws.

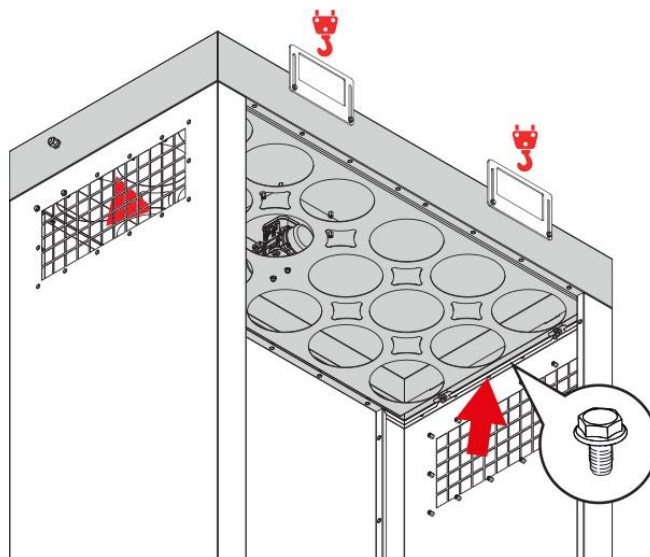

27) For FT 638N, FT 650N, FT 662N, FT 738N, FT 750N and FT 762N units, assemble the central supporting panels.

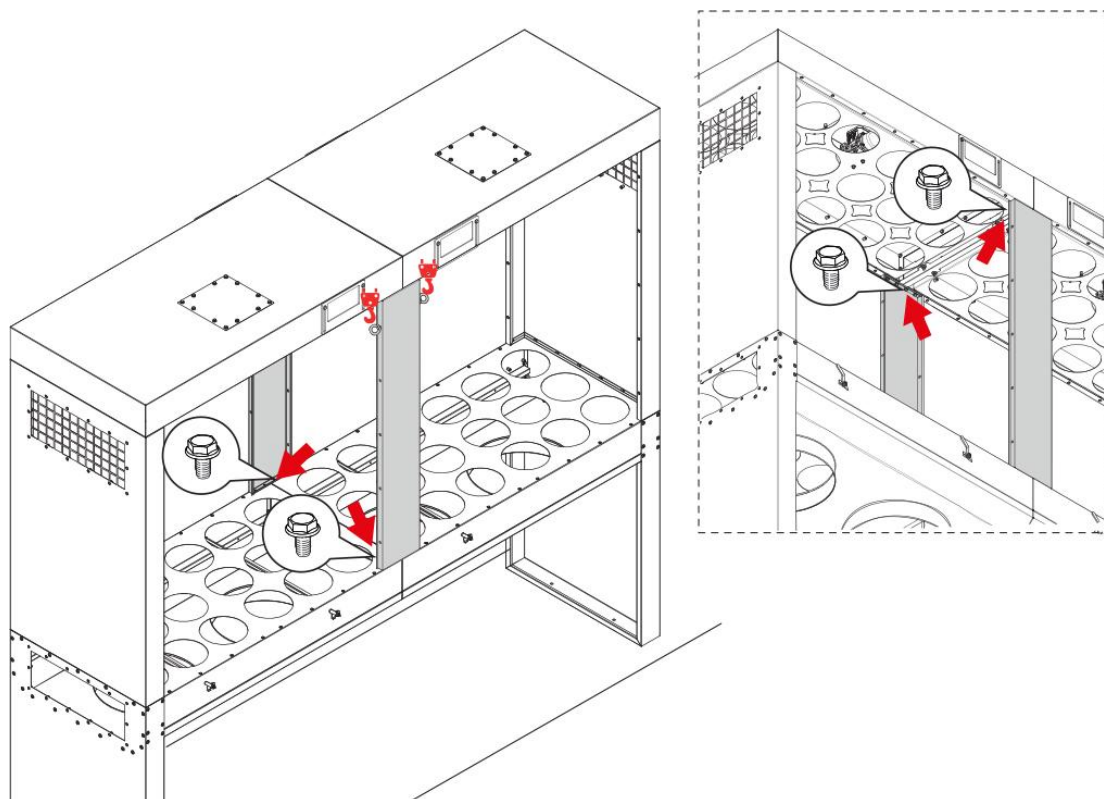

28) Stick the sealing rubber on the rectangular outlet opening of the deflector. Then place the deflector on the unit and screw it in firmly with all the screws.

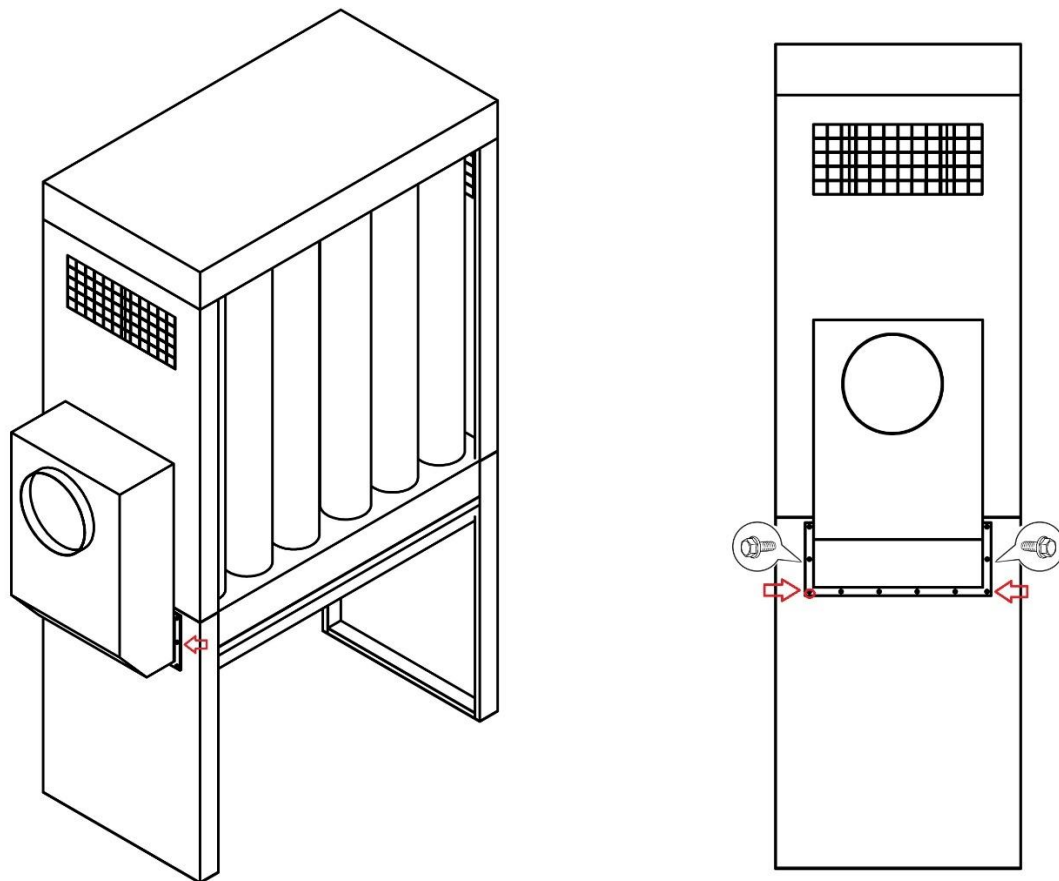

4.3.2 Filter assembly

Deform the snap-ring (inner rubber ring) and attach it to the hole in the panel.



Release the snap-ring and guide it until it lands on the hole.

Check that the snap-ring has sealed the filter around the entire circumference of the hole.

SNAP-RING

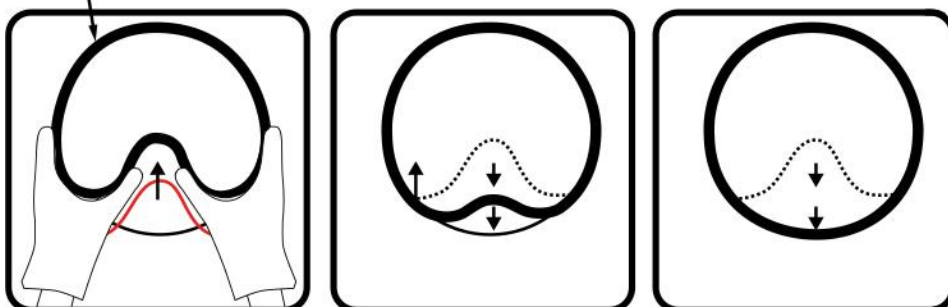

1) Insert the CLOSED end of the sleeve filter into the hole in the roof panel.

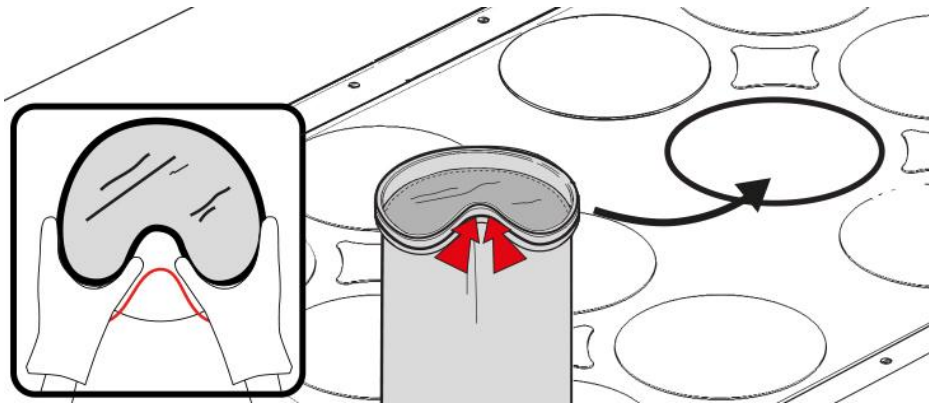

2) Insert the OPEN end of the sleeve filter into the hole in the base.

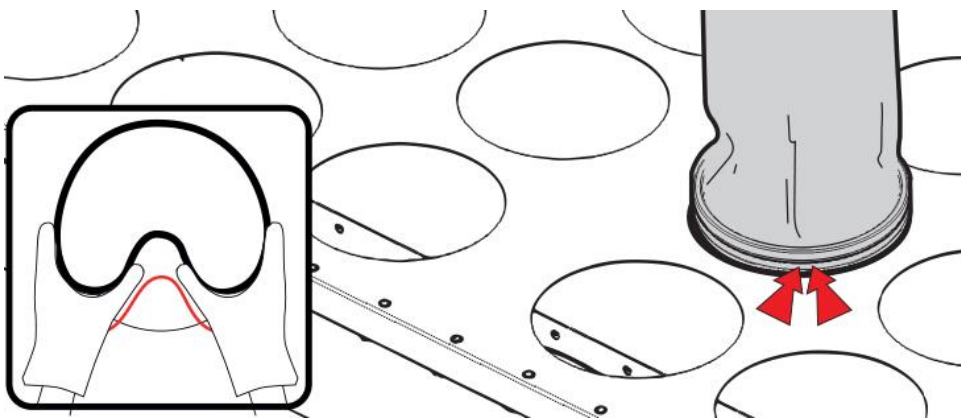

Install the other filters in the same way.



The filters must be installed correctly. Incorrect installation of the filters can lead to leaks. A filter that shows signs of leakage even when installed correctly must be replaced.

4.3.3 Waste bags assembly



Use personal protective equipment during assembly.

Unfold the waste bag along its entire length.

- For PVC waste bags, place the open edge of the bag on the circle element at the bottom of the base. Secure the bag using the clamp with the buckle supplied with the machine.

- For reinforced PE bags and textile waste bags, thread the clamp supplied with the machine through the tunnel of the open edge of the filter. Secure the bag on the circle element using the clamp with the buckle supplied with the machine.

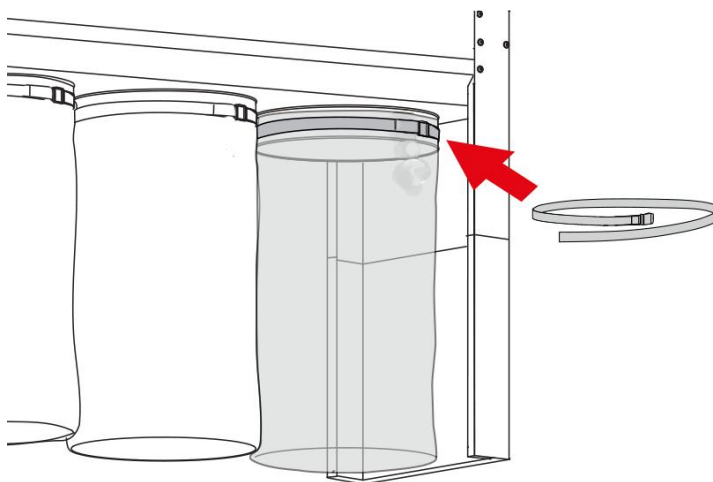

Attach the other waste bags in the same way.



The waste bags must be installed correctly. Incorrect installation of the waste bags can lead to leakage. A waste bag that shows signs of leakage even when installed correctly should be replaced. If a disposable polyethylene bag is used, a simple bag change is required.

4.4 MACHINE HANDLING



***The machine is installed in a fixed position.
The lifting plates are only used for handling the roof.
DO NOT USE lifting plates to handle the machine.***



In order to handle the machine, it is necessary to disassemble it.

See section "4.2 Instructions for machine assembly".

See section "4.5 Installing the machine".

4.5 INSTALLING THE MACHINE



Use personal protective equipment during assembly.



Use the personal protective equipment specified in the manual.



The machine is installed in a fixed position and connected to the ventilator through a fixed galvanized steel pipe.



**The machine is designed for operation in an environment protected from atmospheric weather.
Protect the machine with a suitable cover.**



Please contact ADAMIK Company technical department in advance for correct installation of the machine and correct dimensioning of the suction pipe.



**Before handling the machine, check that the overall dimensions and weights are necessary to carry out work and maintenance without any restrictions on the handling and assembling of the machine.
See section "5.6 Description of perimeter areas".**



**Before starting the installation, the thickness of the cement board and the reinforcement must be dimensioned depending on the geological characteristics of the terrain and/or the structure of the building.
See section "5.4 Technical data" and "5.6 Description of perimeter areas".**



**The machine must be installed on a flat surface and fixed to the ground with dowels and/or chemical screws (from 12 mm).
See section "4.5.2 Anchor bolt layout on the ground".**



Before starting the installation, make sure that the distance between the machine and the working surfaces is sufficient to minimize the risk of inhaling the dust emitted during the phase of emptying the collection bags.



Before starting the installation, ensure that the distance between the machine and the work areas is sufficient to minimize the risk of inhaling the dust emitted during the filter change phase.

- For assembly see section "4.2 Instructions for machine assembly".
- For information on mounting optional components, see section "4.7 Installation of optional accessories".
- If possible, it is recommended to install the machine near utility networks and connect it to collection systems using fixed pipes or hoses.
- Place the filter in an environment with an operating temperature of -10 °C to +40 °C.
- To reduce the sound level due to reverberations, do not place the filter in corners, near walls and ceilings, or on recessed metal structures.

4.5.1 Anchor bolt table

WEDGE ANCHORS - Concrete						
Diameter x length (mm)	Hole depth h_2 (mm)	Hole diameter d_o (mm)	Fastening length l (mm)	Anchoring depth min/max (mm)	Coupling torque T_{inst} (Nm)	Admissible load under traction / cut (kN)
M8 x 39	66	8	71	30 40	15	2,9 / 7,1 6,1 / 7,6
M10 x 66	98	10	106	40 50	30	6,1 / 12 8,5 / 12
M12 x 69	105	12	116	50 65	50	8,5 / 17,9 12,6 / 17,9
M16 x 105	154	16	170	65 80	100	12,6 / 29 17,2 / 31,5

CHEMICAL FIXING (Steel 5.8) - Concrete						
Diameter x length (mm)	Hole depth h_2 (mm)	Hole diameter d_o (mm)	Fastening length l (mm)	Anchoring depth min/max (mm)	Coupling torque T_{inst} (Nm)	Admissible load under traction / cut (kN)
M12	110	14	110	40	7,4	12
M16	125	18	125	60	11,2	22,3
M20	170	24	170	120	19,1	34,9

4.5.2 Anchor bolt layout on the ground

Unit:

FT 616N / 716N A
 FT 625N / 725N A
 FT 631N / 731N A

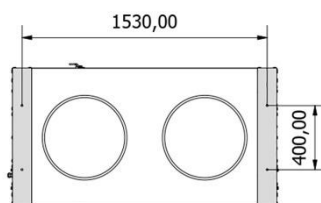

FT 627N / 727N A
 FT 637N / 737N A
 FT 647N / 747N A

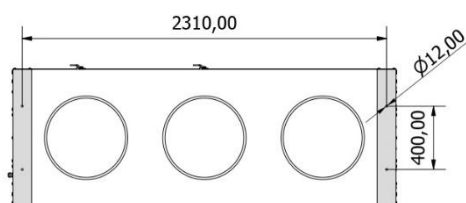

FT 638N / 738N A
 FT 650N / 750N A
 FT 662N / 762N A

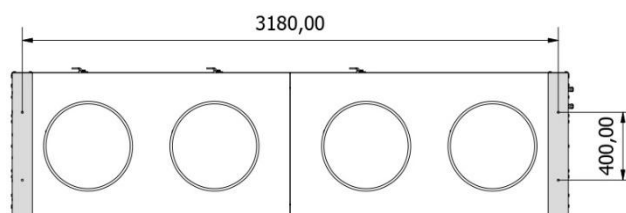

4.6 ELECTRICAL CONNECTION



Use personal protective equipment during assembly.



Use the personal protective equipment specified in the manual.



Verify correct power source before making electrical connections.



Electrical connections must be made by qualified personnel.



Connect the machine to the ground wire using a copper braided wire in accordance with the applicable regulations of the country in which it is installed. The braid can be connected to one of the legs of the filter.

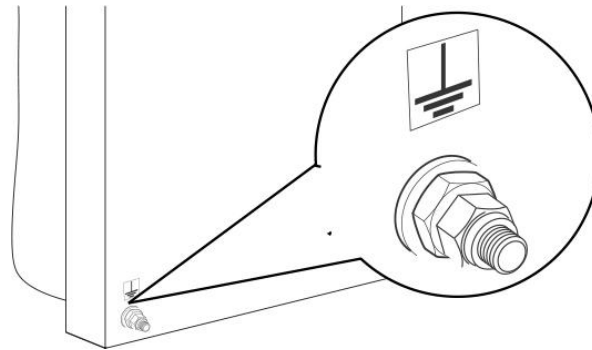

The electrical equipment is designed for the following conditions. If operation beyond the conditions described below is required, an assessment must be made to maintain the electrical equipment in good and safe operation..

- Ambient air temperature during operation: -10 °C to +40 °C in the open air and the average ambient air temperature over a 24-hour period must not exceed +30 °C.
- Humidity: 30 % to 70 %.
- Altitude: up to 1,000 m above sea level.
- Transport and storage conditions: -10 °C to +40 °C.

4.6.1 Vibration motor connection

- 1) Check:
 - the voltage
 - frequency of the mains

The correct data for the use of the machine is given on the label located on the vibration motor or in the table of technical data in the manual.

- 2) Connect the power supply.

For setting, see section "7.1.2 Vibration motor adjustment".

Connect the motor to the electrical network in accordance with the currently valid safety laws. Check for perfect grounding before starting the device.

Check that the supply voltage and frequency match the specifications on the vibration motor nameplate. Including surge protection. Remember that the calibration current of the thermal or earth circuit breaker must not exceed the specifications on the nameplate. Note that the current drawn will vary from 50 to 75 % of the nameplate specifications when the vibration motor is properly installed on the machine.

If an electrical switchboard is supplied, refer to the attached electrical switchboard diagrams. See separately supplied switchboard wiring diagram.



For all optional accessories that require an electrical connection, please contact ADAMIK Company technical support office first. See section "4.7 Installation of optional accessories".



In the event of a power outage, the operator must turn off the power switch and unplug the power cord from the electrical outlet. Restarting is performed according to the instructions in this user manual.



The workplace must be equipped with an appropriate fire extinguisher.



All maintenance work should be carried out by a qualified person.

4.7 INSTALLATION OF OPTIONAL ACCESSORIES



Accessories that are difficult to assemble are not described in the instructions. For all information, it is necessary to contact the technical department of ADAMIK Company.

The following optional extras can be fitted to the machine:

- fairing panels (covered version)
- connection parts to the ventilator
- ventilator
- switchboard...

4.7.1 Installation of fairing panels (covered units FT 7xxN A)



Use personal protective equipment during assembly.

	Number of fairing panels	Terminals
FT 716N / 725N / 731N A	4	4
FT 727N / 737N / 747N A	6	5
FT 738N / 750N / 762N A	8	6



See drawings in section "10.3 List of replaceable spare parts".



The simultaneous presence of at least two people is required to assemble the panels.



After assembling the panels, tighten the nuts and bolts thoroughly.

1)



To lift the panel, assemble eyebolts into the corresponding holes.

See table "4.2.1 Table of handling weights".

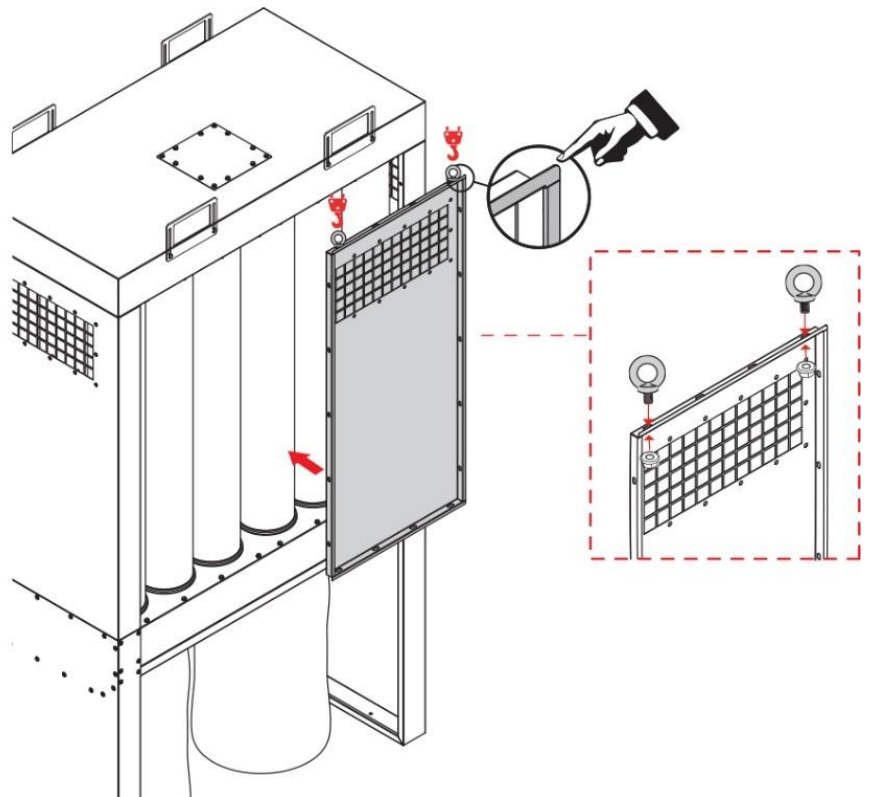

2) Place the panel on the base. Match the holes.



With the help of another person, make sure that the panel does not fall.

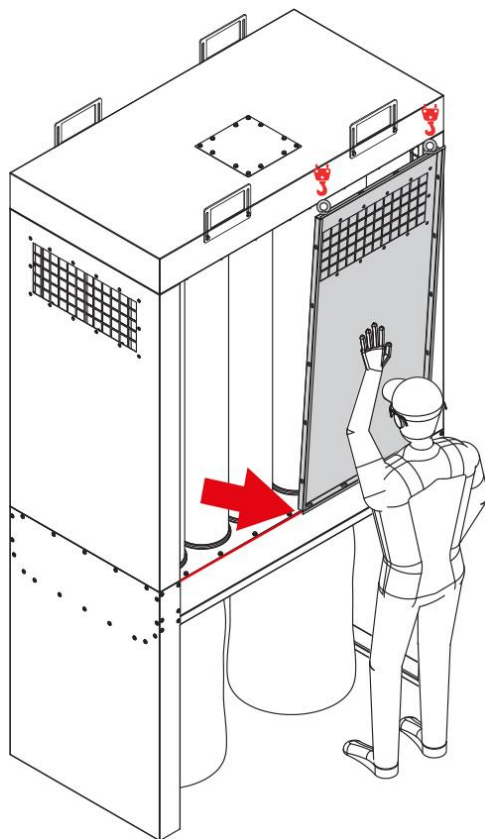

3) Remove the eye bolts.

4) Lock with a washer screws.

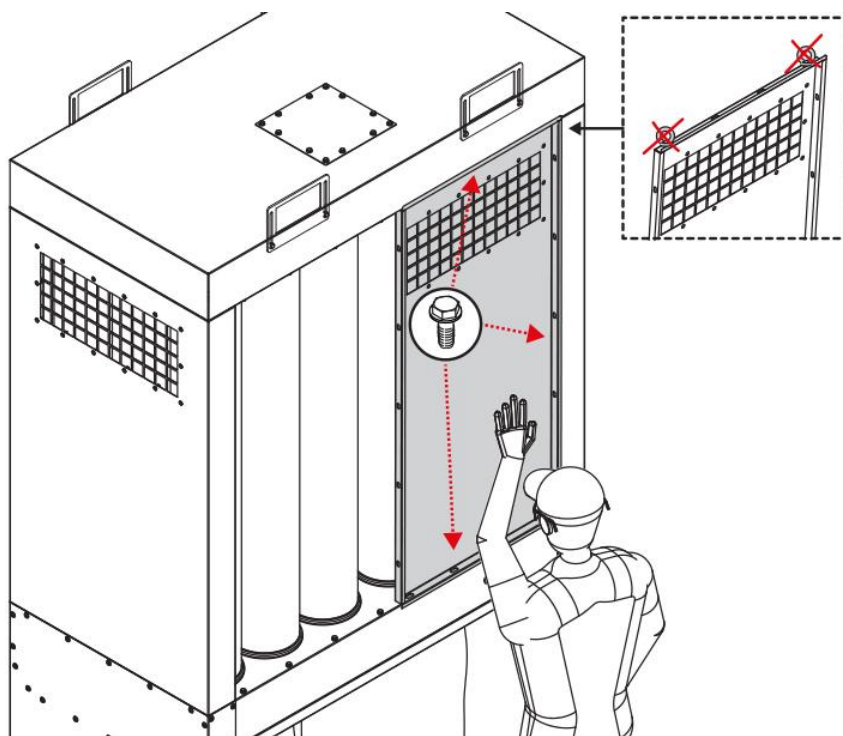

5) Assemble the second panel in the same way.

6) Join the panels with a washer screw and a washer nut.

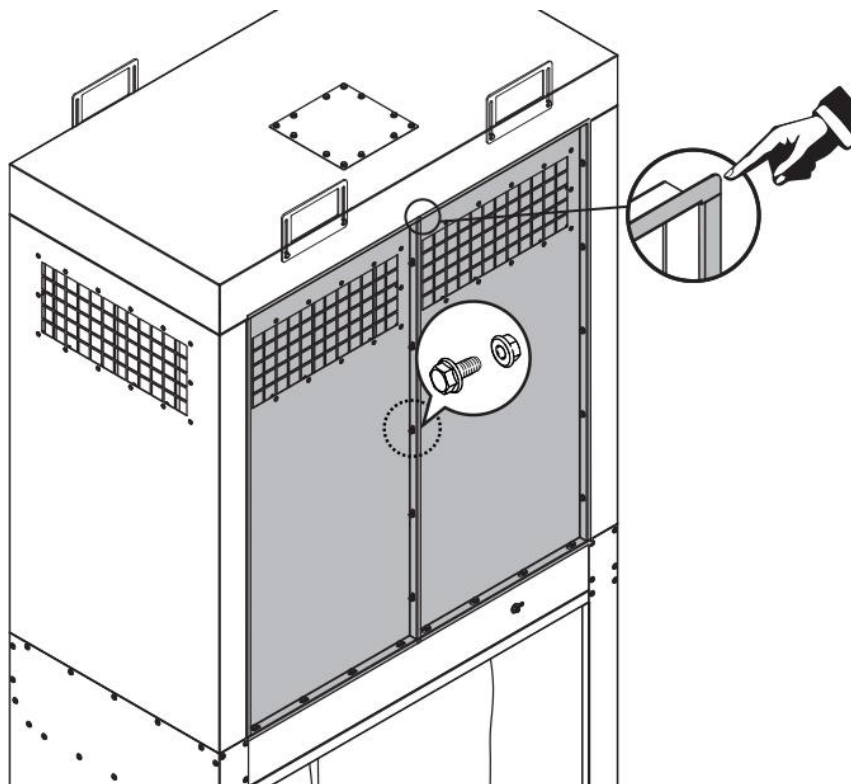

7) Install the air outlet cover terminals (if equipped).

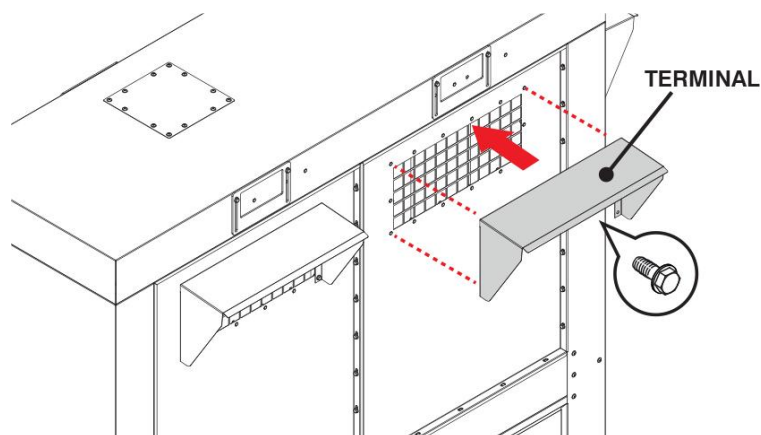

4.7.2 Fan installation (if equipped)



Use personal protective equipment during assembly.

The unit must be connected to the fan.

1) Glue the seal to the rectangular outlet hole of the fan and then screw on the reduction piece (from square to round diameter).

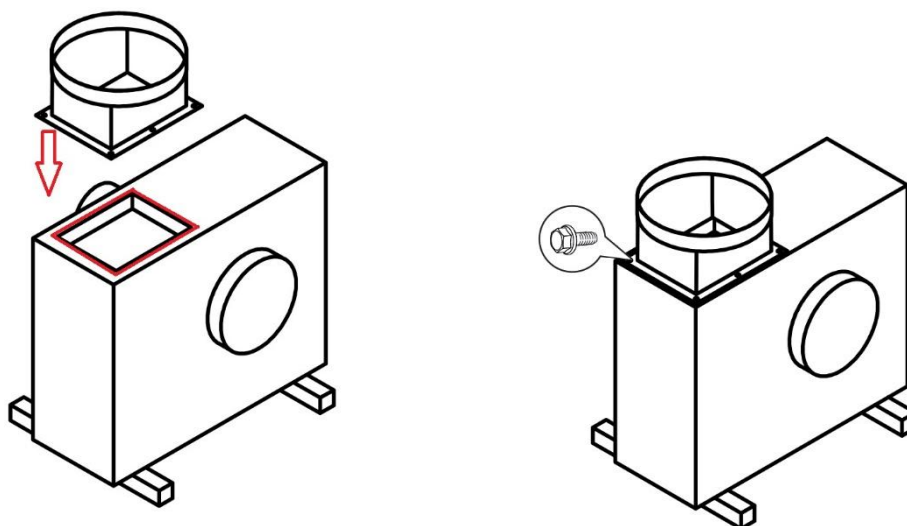

2) Insert the straight pipe into the reduction piece, shortening the length if necessary. Then attach the arc and outer connection piece.

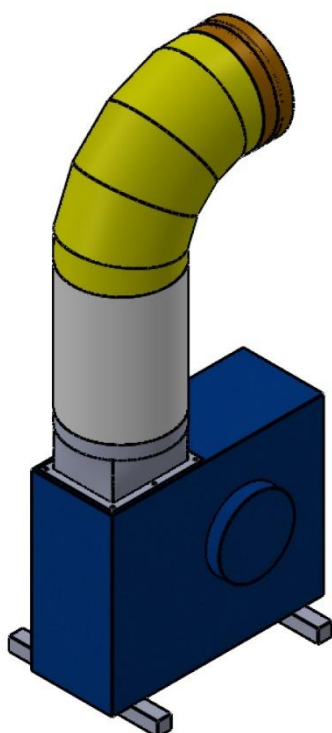

3) Move the fan with the installed elements as close as possible to the circular inlet part on the deflector. At the joints between the individual pieces, rivet or thread the connecting pipes and carefully seal them with sealing tape.

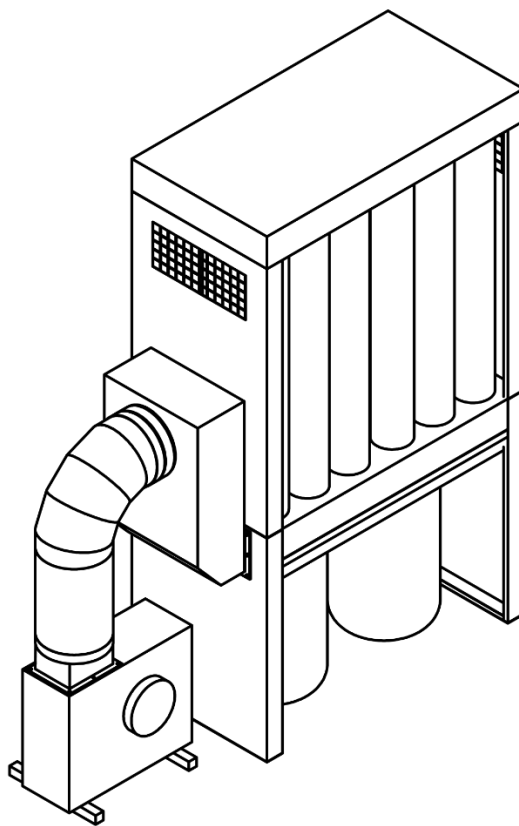
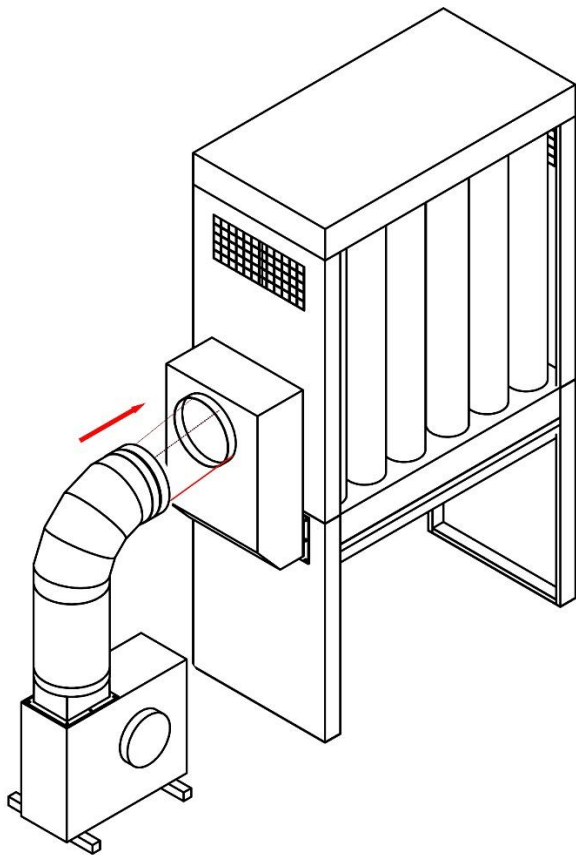

Filter unit after assembly:



open unit



closed unit

4.7.3 Electrical switchboard (if equipped)

The electrical switchboard enables simple and trouble-free starting and stopping of the fan. Enables the automatic start of the regeneration system after the machine has finished working.

Commissioning the control panel should include:

- Inspection of protective and monitoring equipment, including mechanical and electrical locks using automation in the switchboard.
- Connecting the supply cables to the switchboard and insulation measuring.



Before insulation measuring, it is necessary to open the circuit protection: powered with semiconductor devices - measuring, monitoring and auxiliary. Insulation measuring without the above open circuits may damage the equipment during the measurement.

- Checking the correct security settings.
- After correctly reading the insulation condition and checking the security settings, determine the supply voltage.
- Checking the correctness of readings of the monitoring device.
- Sequential connection of output circuits.
- Connection of automatic and control circuits.

Electrical diagram - see the separate instructions for the switchboard.

Attach the switchboard to the wall or to another structure in a place that is easily accessible, without fumes, dripping water, using the holes in the back of the cover. It is important to maintain the vertical position of the switchboard.



The switchboard must not be placed directly on the extraction unit.

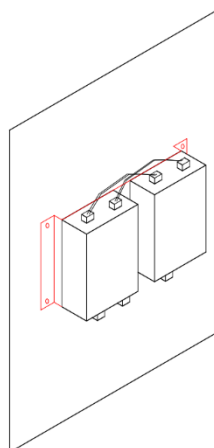

After each short circuit or longer power cut, the entire switchboard or some circuits must be checked and maintained.

Inspection and maintenance of equipment such as switches, circuit breakers, converters, soft starters, controllers and others should be carried out in accordance with the manufacturer's recommendations in the technical and operating documentation of the above equipment.

Service the connectors, contactors and fuse bases only when the fuses are removed or when the main starter is switched off (depending on the type of design). During service work, attention should be paid to any signs of overheating of contactors, extinguishing chambers or other equipment components.

Service must be carried out in accordance with the recommendations of the manufacturer of the given device.

The service of the connection terminals includes checking the strength of the connection of the wires in the terminals and possibly tightening the permitted connection screws.



Subject the switchboards to regular inspections at times according to the environment they are installed in. During the inspection, also clean the interior and tighten the screw connections!



All maintenance work should be carried out by a qualified person.

4.8 TEST INSPECTION



Connect the machine to the ground wire using copper braid in accordance with the applicable regulations of the country in which it is installed.



Check that the filters and waste bags are installed correctly.



Check the tightness of the screws.



Check the direction of rotation of the fan rotor.



Check that the device does not exhibit vibrations or excessive noise.



Check the tightness of the connections of the piping system and the unit. Apply silicone sealant and sealing tape to any leaks **BEFORE STARTING OPERATION.**

Start the extraction device by turning on the switch. After a few seconds of "idle running", start the connected extracted machine.

Check the motor speed to ensure that the direction of rotation corresponds to the arrow on the motor. After two minutes, stop working on the connected machine and switch off the extraction device after a short run (a few seconds).

During operation, it is necessary to monitor in particular:



- the correct function of the extraction device and its smooth operation,
- the cleanliness of the machine and its surroundings,
- load the machine according to its label values and check the temperature of the bearings,

5. TECHNICAL INFORMATION

5.1 MANUFACTURER AND MACHINE IDENTIFICATION

The manufacturer's identification is indicated on the identification plate and on the declaration of conformity.

The plate indicates the manufacturer's data and the technical data necessary for correct and safe use.

		ADAMIK Company, s.r.o. Mitrovická 804 739 21 Paskov Czech Republic			
TYP / TYPE					
VÝROBNÍ ČÍSLO / PRODUCTION NO.					
KAPACITA / CAPACITY		m ³ /h			
PODTLAK / UNDERPRESSURE		Pa			
PŘÍKON / POWER		kW / A			
NAPĚTÍ / VOLTAGE		V / Hz			
VÁHA / WEIGHT		kg			
ROK VÝROBY / PRODUCTION YEAR		20			

5.2 MACHINE DESCRIPTION

The extraction unit consists of a panel structure made of galvanized steel sheet with sleeve filters and continuous extraction of wood chips and sawdust.

The machine, which has a very solid structure, can be supplied as an uncovered or covered version.

The unit is equipped in the standard version with fabric filters and textile waste bags (uncovered version) or PVC waste bags (covered version). Clamps are used to attach the waste bags.

5.3 OPERATION CYCLE DESCRIPTION

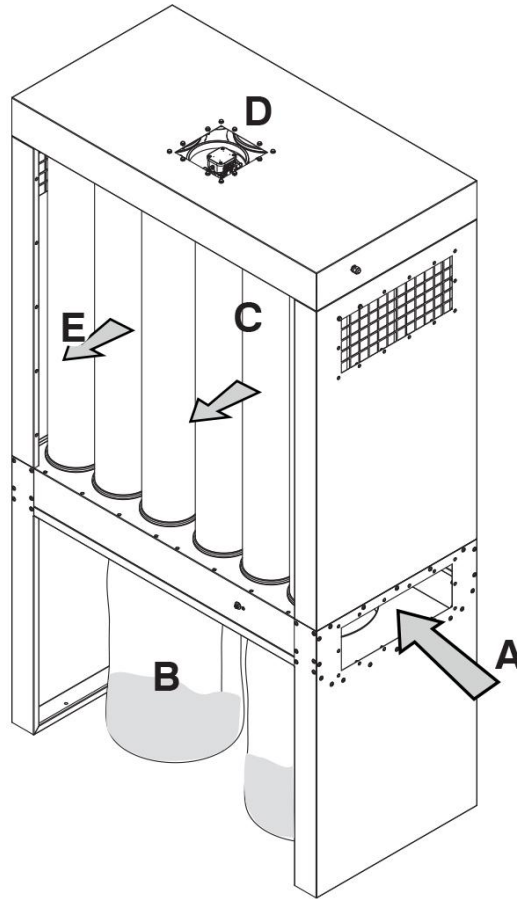

Step	Description
A	Polluted air intake.
B	The heaviest material falls into the collection waste bags.
C	Polluted air passes through sleeve filters that retain dust.
D	Starting the vibration motor releases the dust settled in the bag filters, which then falls into the collection waste bags.
E	Clean air outlet.

The extraction device is designed to extract chips and sawdust with a diameter greater than 0.5 mm.

The extracted material is carried through a pipe distribution to a fabric filter. Separation occurs in the filter, clean air is returned to the working environment, and waste is collected in waste bags.



Uneven filling of waste bags may occur during extraction. The filling of waste bags is influenced by the nature of the material, especially its structure and weight, as well as the method of connection to the pipework and other factors.



Waste bags must be emptied at a maximum level of 3/4 full. Overfilling waste bags may damage the extraction device or its parts.

5.4 TECHNICAL DATA

5.4.1 Dimensions and weight of the unit



The indicated air suction capacity can be achieved in case of optimal conditions. Suction capacity may vary depending on the type of substance to be extracted, its concentration, environmental parameters, hours worked, etc. Please contact ADAMIK Company technical office to determine the correct filter size for the required application.

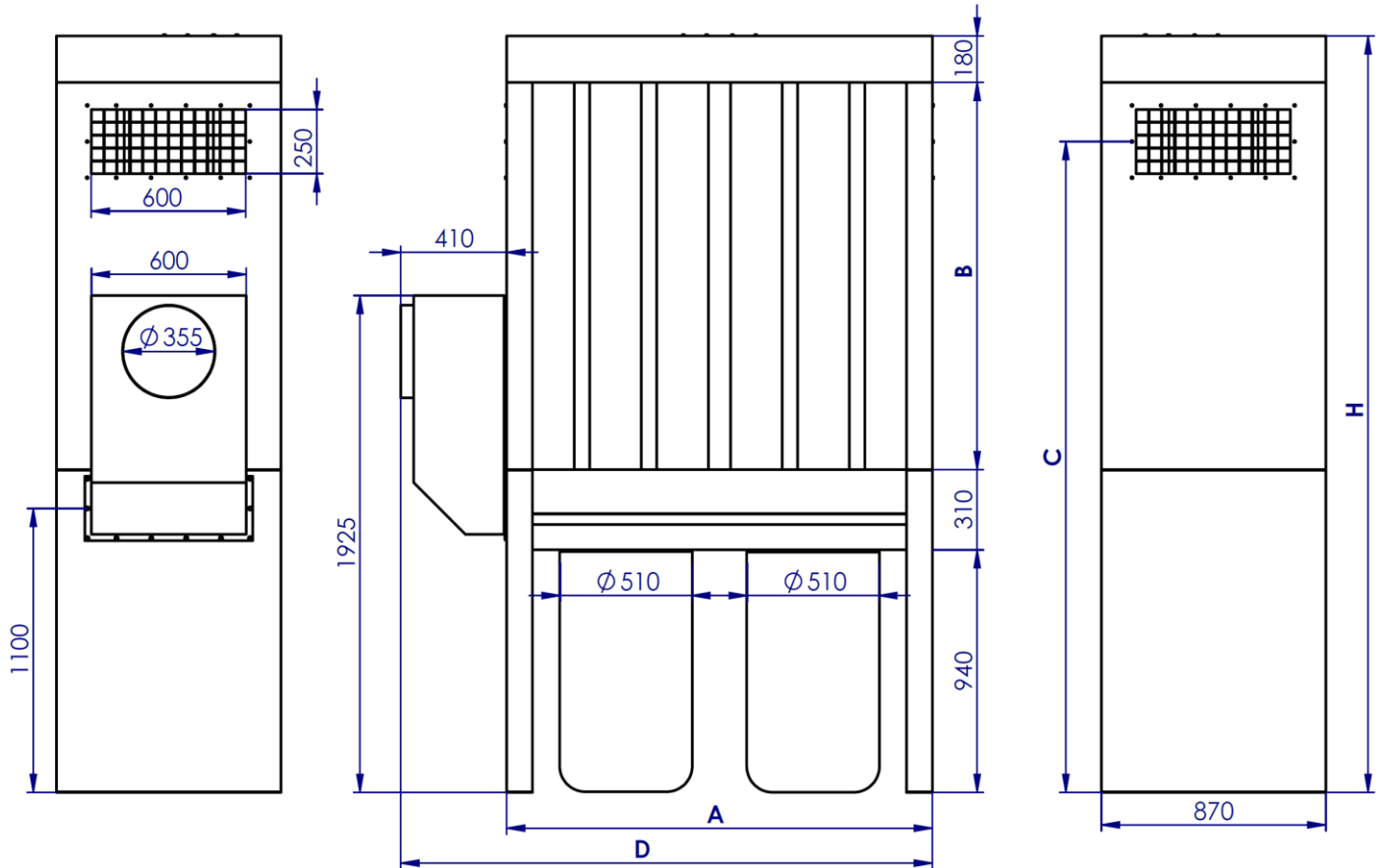

Unit	Dimension (mm)					Weight (kg)
	A	B	C	D	H	
FT 616N / 716N A	1 650	1 500	2 520	2 060	2 930	163 / 211
FT 625N / 725N A	1 650	2 000	3 020	2 060	3 430	181 / 241
FT 631N / 731N A	1 650	2 500	3 520	2 060	3 930	198 / 274
FT 627N / 727N A	2 430	1 500	2 520	2 840	2 930	203 / 275
FT 637N / 737N A	2 430	2 000	3 020	2 840	3 430	223 / 313
FT 647N / 747N A	2 430	2 500	3 520	2 840	3 930	243 / 357
FT 638N / 738N A	3 300	1 500	2 520	3 710	2 930	255 / 351
FT 650N / 750N A	3 300	2 000	3 020	3 710	3 430	278 / 398
FT 662N / 762N A	3 300	2 500	3 520	3 710	3 930	301 / 453

5.4.2 Fan parameters

The units can be combined with any of the following fans supplied by ADAMIK Company:

	Unit	Type	
		VAN 828 3 kW	VAN 831 4 kW
Motor power	kW	3	4
Voltage	V	400	400
Suction capacity (max)	m ³ /h	6 820	8 800
Underpressure (max)	Pa	3 000	3 000
Connection inlet	mm	280	315
Outlet dimension	mm	280 x 220	310 x 250
Noise level	dB	76	79
Height	mm	700	700
Width	mm	654	700
Length	mm	790	790
Weight	kg	85	90

	Unit	Type	
		VAN 831 7,5 kW	VAN 835 9,2 kW
Motor power	kW	7,5	9,2
Voltage	V	400	400
Suction capacity (max)	m ³ /h	9 600	11 200
Underpressure (max)	Pa	4 850	5 000
Connection inlet	mm	315	355
Outlet dimension	mm	370 x 220	370 x 220
Noise level	dB	83	83
Height	mm	848	848
Width	mm	726	726
Length	mm	956	956
Weight	kg	164	204

	Unit	Type
		VAN 840 11 kW
Motor power	kW	11
Voltage	V	400
Suction capacity (max)	m ³ /h	14 000
Underpressure (max)	Pa	5 400
Connection inlet	mm	400
Outlet dimension	mm	370 x 250
Noise level	dB	85
Height	mm	848
Width	mm	756
Length	mm	956
Weight	kg	210

Weight of the connection pipe between the fan and the unit ... 9 kg

The appropriate combination of unit and fan should always be properly consulted with ADAMIK Company technical department.

5.4.3 Air inlet dimensions

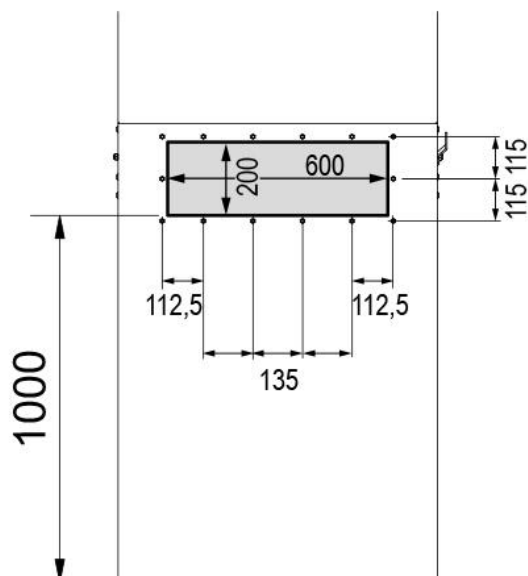

5.4.4 Clean air outlet dimensions

In the case of the covered version, the air extraction can be mounted on the pipe, which allows the discharge of filtered air to the outside environment.

Technical data will be provided by ADAMIK Company.

See drawings in section "10.3 List of replaceable spare parts".

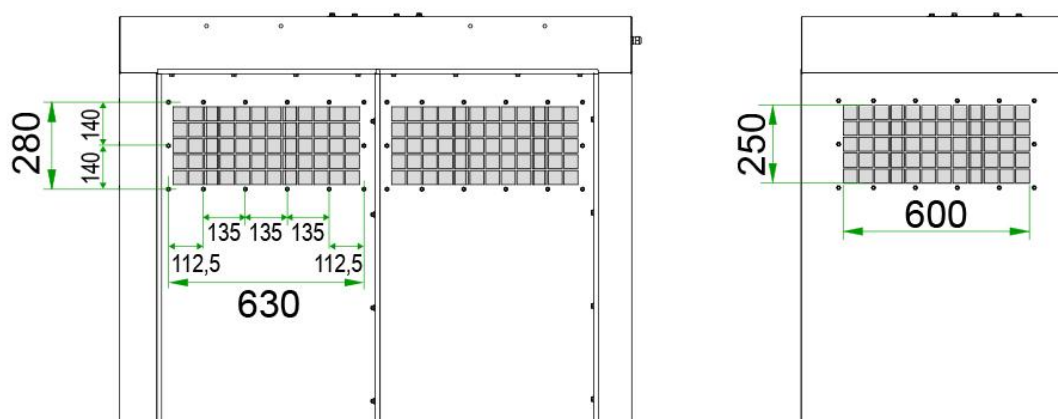

Unit	Number of clean air outlets
FT 716N / 725N / 731N A	4
FT 727N / 737N / 747N A	5
FT 738N / 750N / 762N A	6

5.4.5 Sleeve filter cleaning system (vibrating motor cleaning)

Finer-grained particles retained by bag filters during the cleaning phase are removed from the fabric by cyclic electromechanical shaking.

The operation takes place through vibrations acting on the vibrating plate, which are issued by a vibration motor.

It is recommended to power the vibration motor using time control.

	Value
Number of vibration motors	1 - 2
Vibration motor type	MOTOVIBR.40W-220-240/380-415V-50HZ



**See section "5.4.7 Diagram and electrical values".
See section "7.1 Recommendations for adjustment".**

5.4.6 Noise



To reduce the noise level due to reverberation, we do not recommend installing the unit near corners, walls or metal constructions.



WARNING!!

Check the requirements of the legislation in force in the country of installation and, if necessary, use:

- **Personal protective equipment**
- **Any soundproof screens**

5.4.7 Diagram and electrical values

The electrical connection of the vibration motor can be found in the manual.

See section "4.6 Electrical connection".

See section "7.1.2 Vibration motor adjustment".

If an electrical switchboard is supplied, refer to the attached electrical panel diagrams.

5.4.8 Filter and waste bag parameters



Unit	Filters				Waste bags	
	Designation	Number	Diameter (mm)	Height (mm)	Number	Diameter (mm)
FT 616N / 716N A	F220/1500N	18	220	1 500	2	510
FT 625N / 725N A	F220/2000N	18	220	2 000	2	510
FT 631N / 731N A	F220/2500N	18	220	2 500	2	510
FT 627N / 727N A	F220/1500N	27	220	1 500	3	510
FT 637N / 737N A	F220/2000N	27	220	2 000	3	510
FT 647N / 747N A	F220/2500N	27	220	2 500	3	510
FT 638N / 738N A	F220/1500N	36	220	1 500	4	510
FT 650N / 750N A	F220/2000N	36	220	2 000	4	510
FT 662N / 762N A	F220/2500N	36	220	2 500	4	510

Types of waste bags:

- V510PVC ... PVC waste bag, thickness 0.2 mm
- V510STR ... reinforced PE waste bag
- V510FTEX ... textile waste bag with inspection window

5.5 SAFETY DEVICE DESCRIPTION

The machine is originally equipped with protective systems necessary for working in safe conditions. In the case of interconnection with other machines or almost complete machines, the end user is responsible for evaluating the associated risks.

5.6 DESCRIPTION OF PERIMETER AREAS



During installation, pay attention to the necessary overall dimensions required for machine maintenance.



Consider the dimensions of any optional parts and accessories when installing.



When installing, take into account the dimensions of the collection waste bags and filters, so that they can be removed and reinserted into the machine.



During installation, ensure there is a clear space above the roof panel to access the vibration motor storage area.

When installing, ensure that there is enough space for the full operation of the machine.
(See section "5.4.1 Dimensions and weight of the unit).

Minimum area (dimensions in mm):

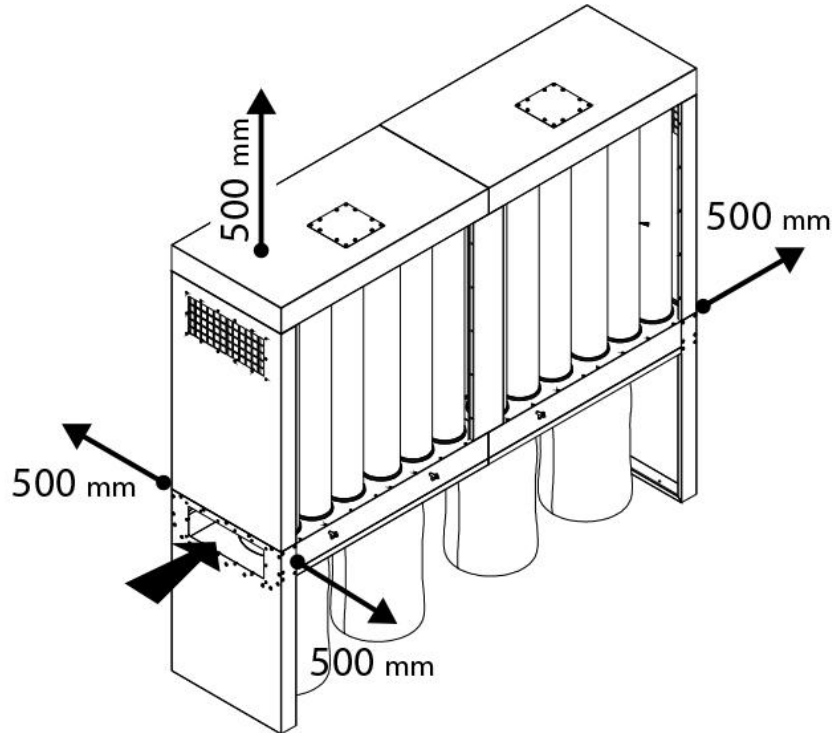

6. INFORMATION FOR USE

6.1 RECOMMENDATIONS FOR USE



The machine is designed for operation under pressure.



The use of flammable sprays, abrasive grinders or other tools that can create sparks or an open flame during welding can cause the filter cloth to catch fire.



The machine is designed for operation in an environment protected from atmospheric weather.



*The machine is designed to operate at an ambient temperature between -10 °C/ +40 °C.
It is recommended to use an operating temperature not higher than 40 °C*



*Any other use of the machine must be approved in advance by ADAMIK Company.
If the user does not have a written authorization, the manufacturer and the supplier refuse any responsibility for damage caused to persons or things, and at the same time the warranty for the line and machinery also expires.*

6.2 CORRECT USE / IMPROPER USE

6.2.1 Type of extracted material

SUITABLE FOR EXTRACTION:

- Wood dust
- Small chips
- Sawdust
- Dry chips and dust without moisture

NOT SUITABLE FOR EXTRACTION:

- Wet materials, liquids
- Work in an environment where there is a risk of explosion
- Flammable or explosive vapors
- Potentially explosive metal powder
- Metal powder
- A powder which may be explosive in nature or reaction
- Material that may cause sparks and hot material

WORKING ENVIRONMENT:

- Material originating from processing operations in the wood industry..

6.3 IN CASE OF FIRE



Before proceeding, ensure that the procedure is carried out safely and using the correct means according to the company's emergency and evacuation plan.



When burning, gases are produced that can be dangerous to health if inhaled. Gases are formed even after the flames are extinguished.

- 1) Stop the machine, disconnect the voltage
- 2) Contact the fire department.
- 3) If conditions are safe, use a portable fire extinguisher (minimum class AB) over 6 kg and try to smother the fire.

7. ADJUSTMENT INFORMATION

7.1 RECOMMENDATIONS FOR ADJUSTMENT

7.1.1 Air flow regulation



The machine is equipped with shutters to adjust the flow of air and polluting material in the hopper.

There are baffles inside that direct the air and the extracted-in material towards the collection waste bags.

Use the handles to adjust the direction of the baffles.

After the installation is complete, it is necessary to adjust the air distribution in the filter chamber (the hopper) by turning the handle in one direction or the other until the lower collection bags are inflated to the same extent. Lock the handles in the position thus obtained.

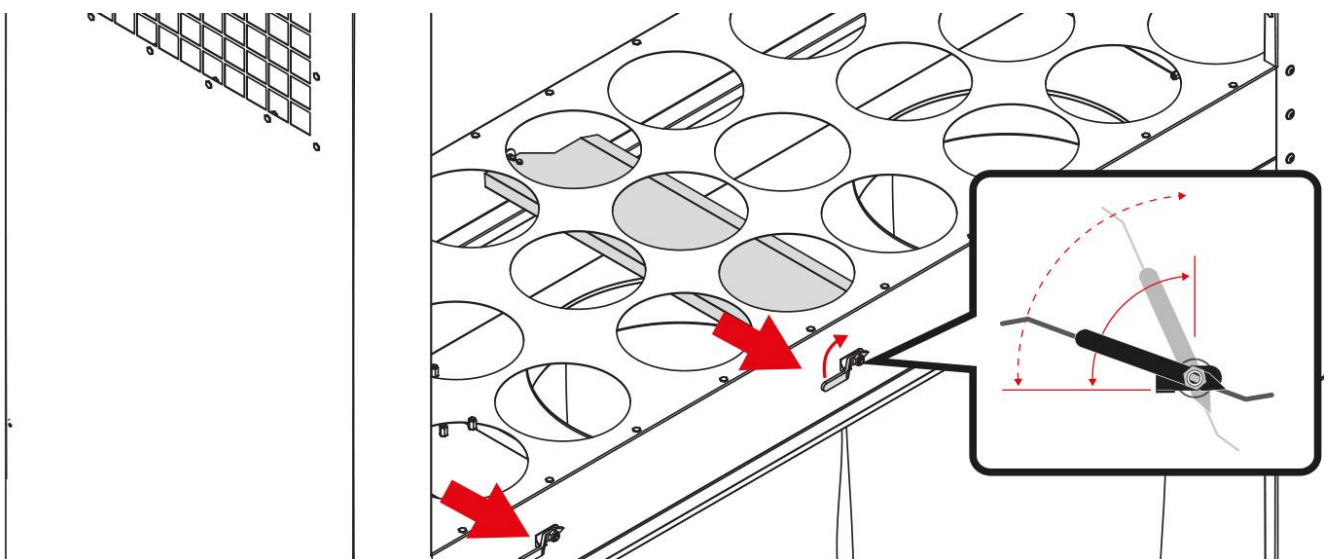

7.1.2 Vibration motor adjustment



The machine is equipped with a vibration motor.

Once the mains connections have been completed in accordance with current safety standards, you can start the vibration motor using an amperometric test clip to check that the absorbed current does not exceed the nameplate value. If so, you need to check whether the flexible part and the frame are properly assembled, or else reduce the vibration amplitude by adjusting the weight until the value of the absorbed current returns to normal.

VIBRATION MOTOR MASS ADJUSTMENT:

The setting of the rotating parts of the vibration motor can be found in the instructions for use and maintenance.

MANUAL CLEANING TIME ADJUSTMENT:

During the working phase of the machine, alternate the on and off time of the vibration motor as follows: 2÷3 minutes on / 15÷20 minutes off.

It is important that the vibrations continue for a period of time when the system is turned off, so that the filter elements will work more efficiently when restarted.

See section "5.4.5 Sleeve filter cleaning system (vibrating motor cleaning)"



Use the vibration cleaning only for a short time while setting up the device.



For units equipped with 2 vibration motors, sequential starting is preferable. The simultaneous operation of two vibration motors can cause resonance phenomena.

8. MAINTENANCE

8.1 MAINTENANCE RECOMMENDATIONS



Carefully read the instructions in this manual before performing any maintenance.



Perform maintenance activities using the personal protective equipment described in the manual.



Do not perform any maintenance while the machine is in operation or connected to a power source.

Before any maintenance or repair work:

- ***Perform several filter cleaning cycles.***
- ***Switch off the vibration motor.***
- ***Switch off the machine.***
- ***Disconnect the power source.***
- ***Empty the waste collection bags.***



Do not use flammable liquids when cleaning the filter unit.



Always wear suitable footwear to prevent electrostatic discharge before performing any maintenance intervention.



To avoid the risk of fire or explosion, never smoke or use an open flame inside or near the filter unit during maintenance or cleaning.



To avoid the risk of fire or explosion, never use mobile phones or other similar devices inside or near the filter unit during maintenance or cleaning.



Empty waste bags regularly before they reach their maximum level to avoid handling heavy overfilled bags.



Always clean the filters after the end of the shift and empty the waste bags as needed.



During extraction, the waste bags may be filled unevenly. The filling of the waste bags is influenced by the nature of the material, especially its structure and weight, as well as the method of connection to the pipe system, and the waste bags must be emptied at a maximum level of 3/4 full. Overfilling the waste bags may lead to damage to the extraction device or its parts.



The extraction device is designed for operation with a maximum number of EIGHT on/off cycles per shift (= 8 hours of operation).



***When operating the extraction device, it is necessary to ensure the minimum allowed amount of air flow, depending on the fan.
Never operate the extraction device if the minimum air flow is not ensured or if all shutters and dampers are deactivated (in the closed position).***



After the end of the work cycle, gradually open the relevant shutters so that the extraction device runs at maximum power and the pipes are cleaned.



Switching the operation of the summer/winter shutters (if equipped) and their control must only be performed when the fan and extraction device are turned off.

8.2 EMPTYING THE WASTE BAGS

- Switch off the extraction device.
- Wait for about 1 minute until the dust has settled.
- Loosen the clamp.
- Remove the waste bag from the extraction unit and carry it outside the workshop.
- Pour the contents of the waste bag into a waste container or a polyethylene bag. Care must be taken to avoid scattering the waste.
- Attach the emptied waste bag back to the extraction unit using the clamp.



***The waste bags must be installed correctly. Incorrect installation of the waste bags can lead to leaks. A bag that shows signs of leakage even when installed correctly must be replaced.
If a disposable PVC bag is used, the bag must be simply replaced.***



***Never wash the waste bags in a washing machine!
Never dry waste bags in a dryer!
There is a risk of damage to the waste bags and the appliance!***

8.3 CLEANING THE FILTERS

The filters are cleaned by vibrating shaker system. If the filter cleaning intervals become shorter or you notice reduced extraction power, the filters must be replaced.



The filters must be installed correctly. Incorrect installation of the filters can lead to leaks. A filter that shows signs of leakage even when installed correctly must be replaced.



***Never wash the filters in a washing machine!
Never dry the filters in a dryer!
There is a risk of damage to the filters and the appliance!***

8.4 TABLE OF SCHEDULED MAINTENANCE INTERVALS



It is recommended to keep a maintenance register to preserve the history of the interventions carried out.

Routine maintenance operations should be performed at the interval shown in the table below.

Operation / Check interval	Very often	Often		Occasionally	
	24 hrs	250 hrs	500 hrs	1 000 hrs	1 500 hrs
Check that the filtration efficiency is sufficient.	X				
Check and replace if necessary sleeves with tears or abrasions.			X		
Check the efficiency of the cleaning system with the vibration motor on.	X				
Check that the shocks caused by the vibration movement have not loosened the fastening to the machine structure.			X		
Check the condition of the power cables.					X
Check the filling level of the collection waste bags.	X				
Check the piping system for clogging and the cleanliness of the shutters (if equipped).		X			
Check the device for vibrations or excessive noise.		X			



Regularly empty collection waste bags before they reach the maximum level to avoid handling heavy weight.

8.5 CLEANING AND DISPOSAL



Perform maintenance activities using the personal protective equipment described in the manual.



Improper cleaning or insufficient replacement of filters can cause contamination to escape into the environment and/or workplace.



Used filters and dust must be stored and disposed of in accordance with the laws in force in the country where the machine is used.



Do not disperse polluting material into the environment. Place the used filters in the protective packaging. Seal the package.



After removing the filters, it is necessary to remove the residual dust on the base of the machine and on the upper attachment of the filters. For proper cleaning of the machine, use an industrial vacuum cleaner with suitable filtration efficiency according to the type of dust being processed.



In the covered version, to change the filters, first remove all the cover panels. See section "4.7.1 Installation of fairing panels (covered units FT 7xxN A).

Installation and replacement of filters - see section "10.3.1. Removing filters".

Installation and replacement of waste bags - see section "10.3.2 Removing waste bags".

9. TROUBLESHOOTING



The following information is intended to help identify anomalies and restore machine operation and efficiency.

Defect	Cause	Possible solutions
The air at the filter unit outlet is not clean enough.	Insufficient efficiency of filters.	Check for cleanliness and remove or replace any parts as necessary.
	The amount and type of dust do not match those in the project.	Rework the project and replace the filter unit.
	The type of filter does not match the type of dust to be extracted.	Rework the project and replace the filter unit.
	Broken or torn filter elements.	Continue to remove and replace them.
Reduction of the exhaust air flow rate.	Filters are not clean.	Remove and clean the filters. If necessary, replace the filters with new ones.
	The connected pipe is clogged.	Remove obstacles.
After a certain period of time when the machine is working properly, dust will begin to be released into the environment.	Broken or torn filter elements.	Continue to remove and replace them.
	Error in fixing filter elements.	Continue with proper fixing. Proceed with the replace them.
	Broken or torn waste bags.	
	An error in the fastening of the collection waste bags.	
The thermal fuse of the vibration motor turns off and stops the vibration motor.	The electrical absorption is higher than the motor vibration plate value.	Check the absorption value set on the thermal fuse.
		Check that the device securing the vibration motor to the machine structure has not loosened.
		adjust the vibration percentage by changing the rotating elements.

10. INFORMATION ON PARTS REPLACEMENT

10.1 ORDERING SPARE PARTS AND ACCESSORIES

If you need to order spare parts or any accessories, please proceed as follows:

1. Look for the machine type and machine serial number - both can be found on the serial plate.
2. If possible, find the sales invoice number.
3. Contact the sales representative from whom you purchased the machine or directly ADAMIK Company at the following contacts:
Email: info@adamikcompany.com
Phone: +420 774 883 858

10.2 RECOMMENDATIONS FOR REPLACEMENT OF SPARE PARTS



Read section "8 Maintenance" before any replacement.



Machine replacement or repair operations are reserved for qualified, trained and authorized personnel employed by the manufacturer or an authorized dealer.



Replace the filters using the protective equipment described in the instructions.



Turn off the machine and disconnect all electrical sources.



Turn off the vibration motor and disconnect all electrical sources.



To avoid the risk of fire or explosion, never smoke or use an open flame inside or near the filter unit during maintenance or cleaning.



To avoid the risk of fire or explosion, never use mobile phones or other similar devices inside or near the filter unit during maintenance or cleaning.



In the covered version, to change the filters, first remove all the cover panels. See section "4.7.1 Installation of fairing panels (covered units FT 7xxN A)".



When replacing the filter elements, pay special attention to handling due to the high incidence of potentially explosive dust.



Filters covered with dust must be stored in suitable closed containers and disposed of in accordance with the regulations in force in the country of installation.



After removing the filters, it is necessary to remove residual dust from the base of the machine and from the space for hanging the filters. For proper internal cleaning of the machine, use an industrial vacuum cleaner with suitable filtration efficiency according to the type of dust being processed.

10.3 LIST OF REPLACEABLE PARTS

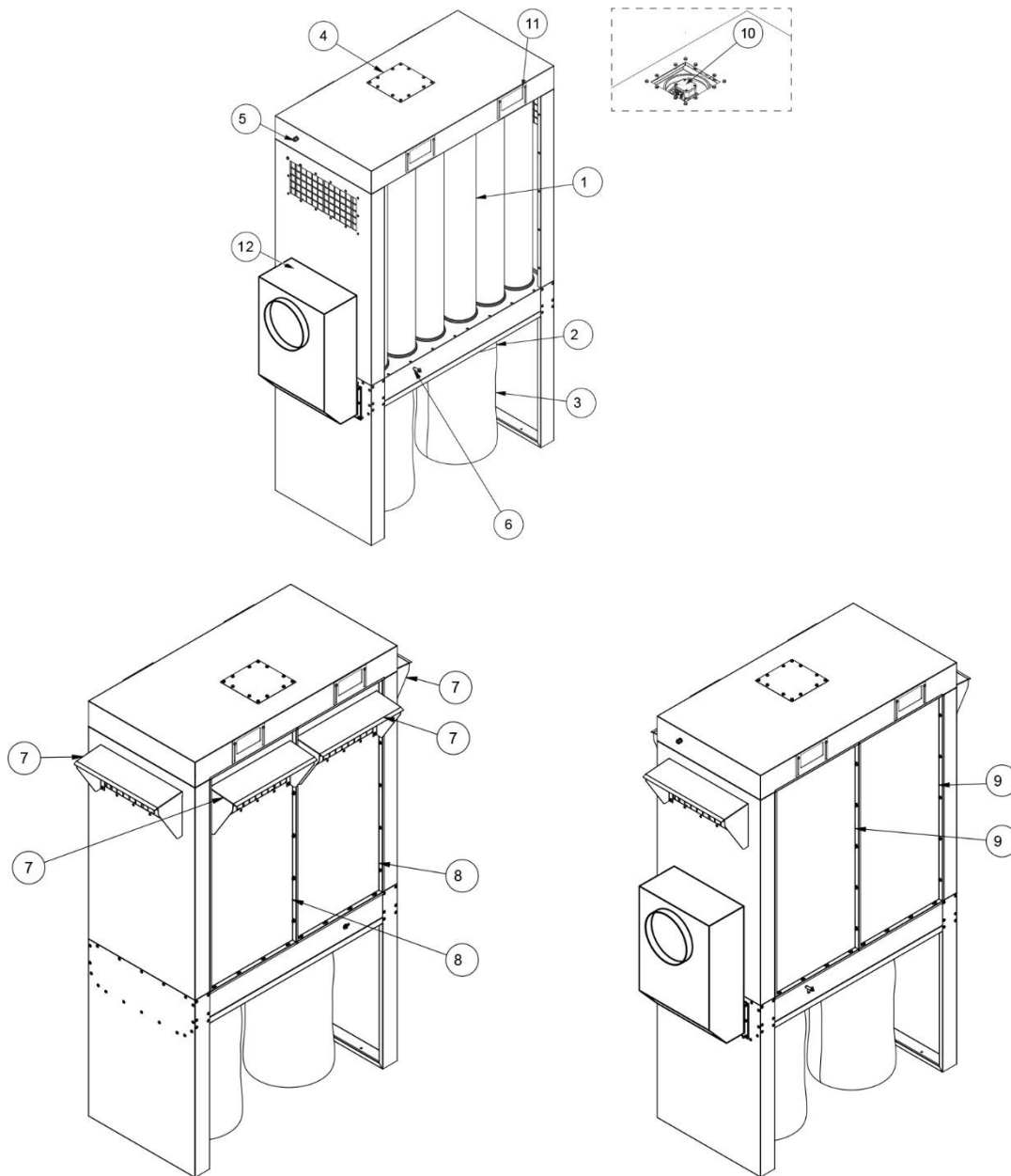

Nr.	Description
1	Sleeve filters F200/1500N / F200/2000N / F200/2500N
2	Clamp UP510
3	Waste bag V510PVC / V510FTEX / V510STR
4	Vibration motor inspection panel
5	Cabel gland
6	Air flow adjustment lever
7	Terminal (covered version only)
8	Fairing panel with clean air outlet (covered version only)
9	Fairing panel closed (covered version only)
10	Vibration motor
11	Sliding lifting plates
12	Deflector

10.3.1 Removing filters



Use personal protective equipment during assembly.



Before any replacement, please read "8 Maintenance" and "10.2 Recommendations for replacement of spare parts".



Perform maintenance activities using the personal protective equipment described in the manual.



Do not disperse polluting material into the environment. Place the used filters in protective packaging, which you close tightly.

- 1) Carry out one cycle of knocking the filters with the vibration motor (approx. 3 minutes).
- 2) Turn off the vibration motor.
- 3) Turn off the machine and disconnect all electrical sources.



FOR COVERED UNITS:

To replace the bag filters, remove the cover panels.

See section "4.7.1 Installation of fairing panels (covered units FT 7xxN A)".



First, release the UPPER snap-ring of the sleeve filter.

- 4) Remove the sleeve filters from the mount:

See section "4.3.2 Filter assembly".

- To release the filter, deform the snap-ring (inner rubber ring), see picture.

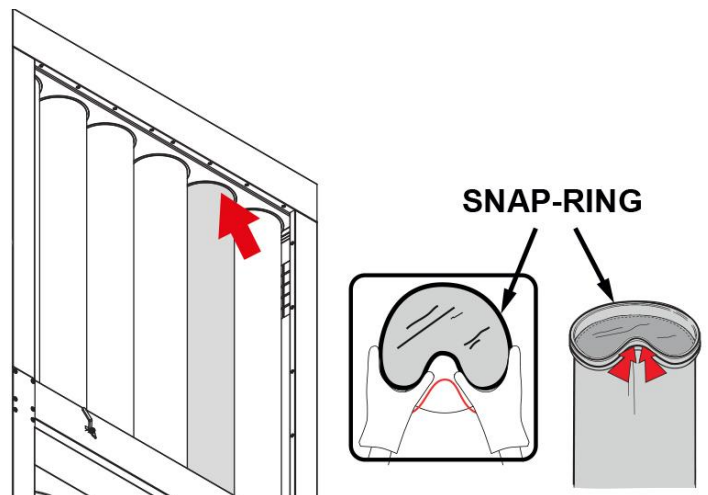

- Release the snap-ring from the lower filter attachment.



***This action may cause the dispersion of polluting dust.
When replacing, pay special attention to the handling of the filters.***

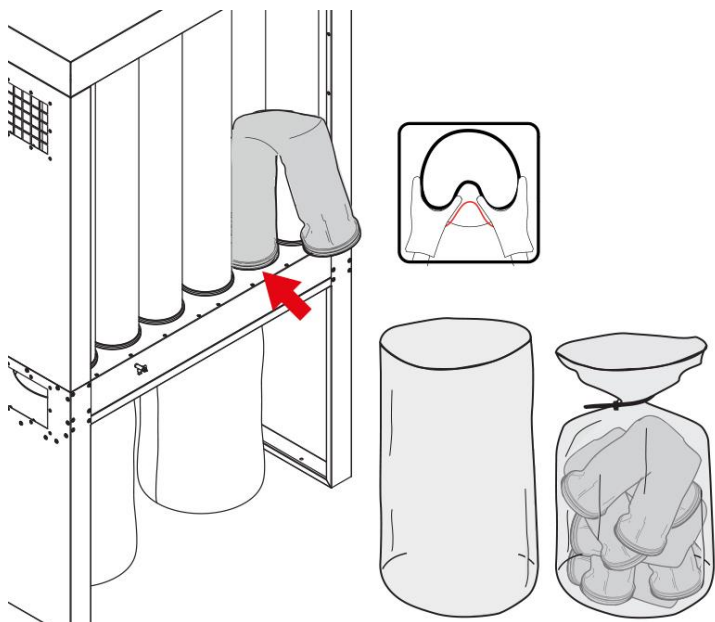

5) Put the dirty filters in the appropriate packaging and close it.
See section "8.5 Cleaning and disposal".

To install filters - see section "4.3.2 Filter assembly".

10.3.2 Removing waste bags



Use personal protective equipment during assembly.



Before any replacement, please read "8 Maintenance" and "10.2 Recommendations for replacing spare parts"



Perform maintenance activities using the personal protective equipment described in the manual.



Empty waste collection bags regularly before they reach the maximum level of filling.



Do not disperse polluting material into the environment. Place the used waste bags in protective packaging, which you close tightly

- 1) Release the buckle of the clamp.
- 2) Remove the waste bag from under the machine and empty it.

Assembly see section "4.3.3 Waste bags assembly".

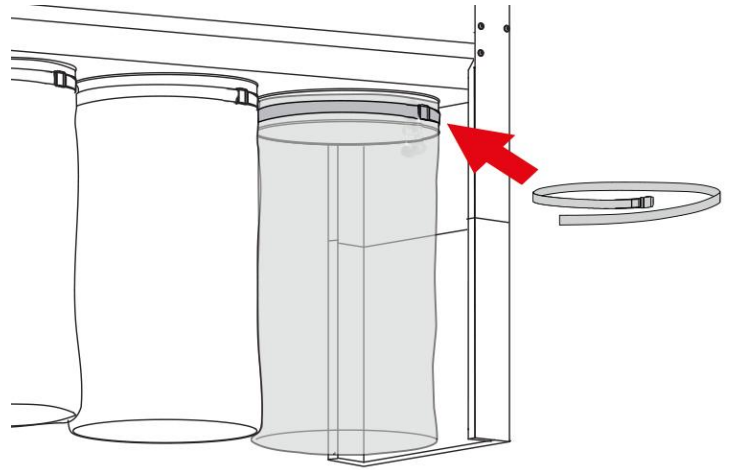

10.4 OPTIONAL EQUIPMENT

















Use personal protective equipment during assembly.

Accessories that are difficult to assemble are not described in the instructions. For any information contact ADAMIK Company directly.

10.5 DECOMMISSIONING

The machine does not present special problems for decommissioning. Care must be taken to prevent unauthorized persons from starting the machine. Comply with the laws in force in the country of use for any legal and tax aspects (any reports, complaints, etc.).

Component	Material	Treatment	Note
Unit construction	Steel	 RECYCLABLE STEEL	
Sleeve filters	Polyester		Place clogged filters in a sealed protective package. Information on the correct disposal of these items can be found in the current valid regulations of your state.
		 	 Place clogged filters in a sealed protective package. Information on the correct disposal of these items can be found in the current valid regulations of your state.

Součást	Materiál	Zpracování	Poznámka
Electrical controls and components	OEEZ		Information on the correct disposal of these items can be found in the currently valid regulations of the country where the machine is installed.
Textile waste bags	Polyester		Place clogged waste bags in sealed protective packaging. Information on the correct disposal of these items can be found in the current valid regulations of your state.
		 	 Place clogged waste bags in sealed protective packaging. Information on the correct disposal of these items can be found in the current valid regulations of your state.
PVC and PE waste bags	PVC, PE		Place clogged waste bags in sealed protective packaging. Information on the correct disposal of these items can be found in the current valid regulations of your state.
		 	 Place clogged waste bags in sealed protective packaging. Information on the correct disposal of these items can be found in the current valid regulations of your state.



SPECIAL WASTE.

Use appropriate protection to avoid contact with particles that may have been released. Information on the correct disposal of these items can be found in the current applicable regulations.



STEEL.

Fully recyclable.



NON-RECYCLEABLE MATERIAL.

Take to the appropriate landfill / collection facility.



RECYCLABLE MATERIAL.

Fully recyclable.



OEEZ.

Information on the correct disposal of these items can be found in the current applicable regulations.

11. WARRANTY

The warranty period is 12 months from the date of sale.

The warranty does not cover malfunctions caused by improper handling or use for purposes other than those specified in the operating instructions.

11.1 RESPONSIBILITY FOR DEFECTS

By law, the manufacturer is liable under the contracts for consideration (purchase, work, etc.) for the fact that the goods or performance at the time of delivery are free of defects. Liability applies to all parts (except point 11.3) as well as to labor, transport and travel costs. Any consequential damages are excluded.

Consumer buyer - legal liability for defects for a period of 2 years from the date of issue of the sales document.

Buyer entrepreneur - pays liability for defects for 6 months from the date of issue of the sales document. In single shift operation. Additional arrangements always require written form, oral promises are not valid.

11.2 VOLUNTARY ADDITIONAL WARRANTY

Compared to the statutory liability for defects, a voluntary additional guarantee is a voluntary undertaking that the goods or performance beyond the statutory liability for defects will remain free of defects for a certain period of time. The guarantee requires a written form. Oral agreements are excluded. The warranty only applies to mechanical parts (with the exception of point 11.3), it does not apply to labor, transport and travel costs. Any consequential damages are excluded.

The seller provides a **warranty for a period of 12 months or a maximum of 1600 operating hours for parts of mechanical components** (except point 11.3).

The seller provides a **warranty for 6 months for spare parts** (except point 11.3).

In the case of used goods, only the statutory provisions on liability for defects apply, which is 1 year for the consumer buyer and 3 months for the entrepreneur buyer.

11.3 EXCLUSIONS FROM RESPONSIBILITY FOR DEFECTS AND WARRANTY

- If the defect did not occur at the time of delivery.
- In case of damage to the goods during transport (these damages must be resolved with the shipping company upon receipt, all shipments are sent insured).
- Defects caused by improper use or overloading (classification of hobby use, craftsman, professional, industrial).
- Defects caused by unprofessional installation, unprofessional commissioning, unprofessional handling, operation or storage or neglect of care of the goods.
- If the prescribed operating or installation conditions are not observed (main board of the machine, electrical distribution, compressed air distribution, exhaust distribution).
- If a defect has occurred due to improper handling or external forces (eg. scratches, dents, twists, etc.).
- No liability is accepted for all consequential damages (such as unforeseeable damages).

- No liability is accepted for wear related to the appearance and as a result of everyday use (eg. paint damage, scratches, etc.).
- Does not accept responsibility for any defects caused by pollution.
- No liability is accepted for defects caused by non-compliance with the instructions in the operating instructions or maintenance instructions or arising from use that is in conflict with the operating instructions or normal use.
- No liability is accepted for consumable parts (eg. bearings, belts, gears, segments, threaded rods, threaded nuts, teeth, gears, chip breakers...) as well as plastic parts (eg. handles, levers, stickers, plugs, covers, squeegees, roller carriers, rubberized rolls...).
- No liability is accepted for defects caused by modifications, repairs, sharpening and manipulations not performed by the authorized personnel of the manufacturer or certified dealer or the authorized service of the manufacturer or certified dealer.
- No liability is accepted for defects resulting from corrosion, fire or water damage.
- No liability is accepted for defects resulting from external influences, such as 2-phase operation, faulty electrical protection, undervoltage, overvoltage (visibly burned components or printed circuits) except for normal deviations, lightning strikes.
- Liability according to the valid regulations of the given country for motors, electric switches/ switches, electric control boards, etc.
- Violation of the protective seal, information label or serial number, unless damage occurs during normal use. Seals and serial numbers are an integral part of the goods and do not limit the buyer's right to use and manipulate the goods to the full extent of what the goods are intended for.
- Electrical use of goods in conditions that do not correspond to their temperature, dust, humidity, chemical and mechanical influences of the environment, which is directly determined by the seller or manufacturer.
- Damage caused by excessive loading or use contrary to the conditions stated in the documentation or general principles.
- Performing an unqualified intervention or changing parameters.
- Goods that have been adjusted by the customer (painting, bending, etc.), if the defect was a result of this adjustment.
- Damage from natural elements or force majeure.
- The use of incorrect or non-genuine consumables, or any damage resulting therefrom, unless such use is normal and has not been ruled out in the operating instructions.

12. TERMS OF SERVICE

In the event of any malfunction during the warranty or post-warranty period, contact:

ADAMIK Company, s.r.o.
 Mitrovická 804
 739 21 Paskov
 Czech Republic
 Tel. +420 774 883 858
 E-mail: info@adamikcompany.com



CE DECLARATION OF CONFORMITY CE PROHLÁŠENÍ O SHODĚ

The manufacturer / Výrobce: ADAMIK Company, s.r.o.
Registered office / Sídlo společnosti: Mitrovická 804, 739 21 Paskov, Czech Republic

whose responsibility for the relevant technical document is / jehož odpovědnost za příslušný technický dokument nese:

Name / Jméno Ing. Petr Adamík

declares under his own responsibility that the machine / na svou vlastní zodpovědnost prohlašuje, že strojní zařízení:

Product / Výrobek: Dust filtering unit, with shaker /
Odsávací a filtrační jednotka, s oklepem
Type / Typ: FT 616N A, FT 625N A, FT 631N A, FT 627N A, FT 637N A,
FT 647N A, FT 638N A, FT 650N A, FT 662N A
in combination with radial ventilator for air transport of
sawdust, chips and dust without risk of explosion / *v kombinaci*
s radiálním ventilátorem pro dopravu vzduchu pilin, třísek a
prachu bez rizika výbuchu
Type / Typ: VAN 828 3 kW, VAN 831 4 kW, VAN 831 7,5 kW,
VAN 835 9,2 kW, VAN 840 11 kW

Serial number / Výrobní číslo:
Year of production / Rok výroby:

1) complies with the requirements given in the Machine Directive 2006/42/CE of the European Parliament and Council dated 17 May 2006, regarding the machine and that modifies the Directive 95/16/CE (merging), and respects the following Essential Safety and Security Requirements (Annex I):
1.1.2 - 1.1.3 - 1.1.5 - 1.3.1. - 1.3.2 - 1.4.1 - 1.4.2.1 - 1.4.2.2 - 1.5.2 - 1.7.1 - 1.7.1.1 - 1.7.2 - 1.7.4.
The relevant technical documentation is compiled in accordance with Annex VII B of Machine Directive 2006/42/CE.

2) complies with the requirements given in the:

- Directive 73/23/EC and 93/68/EC (Government Regulation No. 17/2003 Coll.)
- Directive 2004/108/EC (Government Regulation No. 616/2006 Coll.).

Defined by the EC directives for low-voltage installations 73/23/EEC and 93/68/EEC.

Defined by EC machinery standard 98/37/EEC Annex II A. Fans in air handling systems working with air from non-explosive buildings. These devices cannot be put into operation without first reading the assembly instructions and safety information.

The following harmonized standards are applied:

- EN 60 034-1 Rotating electrical machines; determination of nominal values and performance
- EN 60 204-1 Safety of machinery; Electrical equipment of machines; General requirements
- EN ISO 12100-1:2003 (ČSN EN ISO 12100-1:2004) Safety of machinery - Basic concepts, general principles for construction - Part 1: Basic terminology, methodology.
- EN ISO 12100-2:2003 (ČSN EN ISO 12100-2:2004) Safety of machinery - Basic concepts, general principles for construction - Part 2: Technical principles.
- EN 294:1993 Safety of machinery; Safe distances to avoid reaching dangerous places with the upper limbs.

- EN ISO 13857 Safety of machinery - Safe distances to avoid reaching dangerous areas
- ČSN EN 349 Safety of machinery. Smallest gaps to avoid compression of parts of the human body
- ČSN EN 614 Safety of machinery – Ergonomic design principles
- ČSN EN 953 Safety of machinery - Protective covers - General requirements for the design and production of fixed and movable protective covers.
- ČSN EN 1037 Safety of machinery - Prevention of unexpected start-up

The manufacturer undertakes to transmit all the papers, in response to a reasoned request of the competent national authorities, with relevant informations on this almost-machine and leaves intact his intellectual property rights. /

1) *splňuje požadavky dané Směrnicí o strojních zařízeních 2006/42/CE Evropského parlamentu a Rady ze dne 17. května 2006 týkající se strojního zařízení a o změně směrnice 95/16/ES (přepracované znění), a respektuje následující základní požadavky na bezpečnost a zabezpečení (příloha I):*

1.1.2 - 1.1.3 - 1.1.5 - 1.3.1. - 1.3.2 - 1.4.1 - 1.4.2.1 - 1.4.2.2 - 1.5.2 - 1.7.1 - 1.7.1.1 - 1.7.2 - 1.7.4.

Příslušná technická dokumentace je sestavena v souladu s přílohou VII B Směrnice o strojních zařízeních 2006/42/CE.

2) *splňuje požadavky dané směrnicemi:*

- *Směrnice 73/23/ES and 93/68/ES (nařízení vlády č. 17/2003 Sb.)*
- *Směrnice 2004/108/ES (nařízení vlády č. 616/2006 Sb.)*

Definované směrnicemi EC pro nízkonapěťové instalace 73/23/EEC a 93/68/EEC.

Definovaná normou EC o strojních zařízeních 98/37/EEC, Příloha II A. Ventilátory ve vzduchotechnických systémech pracujících se vzduchem z budov bez rizika výbuchu. Tato zařízení není možné uvést do provozu bez předchozího přečtení montážního návodu a bezpečnostních informací.

Uplatněny jsou následující harmonizované normy:

- *EN 60 034-1 Rotační elektrické stroje; stanovení jmenovitých hodnot a výkonu*
- *EN 60 204-1 Bezpečnost strojních zařízení; Elektrická zařízení strojů; Všeobecné požadavky*
- *EN ISO 12100-1:2003 (ČSN EN ISO 12100-1:2004) Bezpečnost strojních zařízení - Základní pojmy, všeobecné zásady pro konstrukci - Část 1: Základní terminologie, metodologie.*
- *EN ISO 12100-2:2003 (ČSN EN ISO 12100-2:2004) Bezpečnost strojních zařízení - Základní pojmy, všeobecné zásady pro konstrukci - Část 2: Technické zásady.*
- *EN 294:1993 Bezpečnost strojních zařízení; Bezpečné vzdálenosti k zabránění dosahu k nebezpečným místům horními končetinami.*
- *EN ISO 13857 Bezpečnost strojních zařízení - Bezpečné vzdálenosti k zamezení dosahu do nebezpečných prostor*
- *ČSN EN 349 Bezpečnost strojních zařízení. Nejmenší mezery k zamezení stlačení částí lidského těla*
- *ČSN EN 614 Bezpečnost strojních zařízení – Ergonomické zásady navrhování*
- *ČSN EN 953 Bezpečnost strojních zařízení - Ochranné kryty - Všeobecné požadavky pro konstrukci a výrobu pevných a pohyblivých ochranných krytů.*
- *ČSN EN 1037 Bezpečnost strojních zařízení - Zamezení neočekávanému spuštění*

Výrobce se zavazuje předat všechny dokumenty na základě odůvodněné žádosti příslušných vnitrostátních orgánů s příslušnými informacemi o tomto téměř stroji a ponechává nedotčena svá práva duševního vlastnictví.

Place, date / Místo, dne: Paskov, 1.3.2024

Legal representative / Zákonný zástupce společnosti:

Ing. Petr Adamík, CEO / Ing. Petr Adamík, jednatel společnosti

ADAMIK Company, s.r.o.
 CZ-190 00 PRAHA 9, Pajkova 910/9
 IČ: 26845318



CE DECLARATION OF CONFORMITY CE PROHLÁŠENÍ O SHODĚ

The manufacturer / Výrobce: ADAMIK Company, s.r.o.
Registered office / Sídlo společnosti: Mitrovická 804, 739 21 Paskov, Czech Republic

whose responsibility for the relevant technical document is / jehož odpovědnost za příslušný technický dokument nese:

Name / Jméno Ing. Petr Adamík

declares under his own responsibility that the machine / na svou vlastní zodpovědnost prohlašuje, že strojní zařízení:

Product / Výrobek: Dust filtering unit, closed, with shaker /
Odsávací filtrační jednotka, krytovaná, s oklepem
Type / Typ: FT 716N A, FT 725N A, FT 731N A, FT 727N A, FT 737N A,
FT 747N A, FT 738N A, FT 750N A, FT 762N A
in combination with radial ventilator for air transport of
sawdust, chips and dust without risk of explosion / *v kombinaci*
s radiálním ventilátorem pro dopravu vzduchu pilin, třísek a
prachu bez rizika výbuchu
Type / Typ: VAN 828 3 kW, VAN 831 4 kW, VAN 831 7,5 kW,
VAN 835 9,2 kW, VAN 840 11 kW

Serial number / Výrobní číslo:
Year of production / Rok výroby:

1) complies with the requirements given in the Machine Directive 2006/42/CE of the European Parliament and Council dated 17 May 2006, regarding the machine and that modifies the Directive 95/16/CE (merging), and respects the following Essential Safety and Security Requirements (Annex I):

1.1.2 - 1.1.3 - 1.1.5 - 1.3.1 - 1.3.2 - 1.4.1 - 1.4.2.1 - 1.4.2.2 - 1.5.2 - 1.7.1 - 1.7.1.1 - 1.7.2 - 1.7.4.

The relevant technical documentation is compiled in accordance with Annex VII B of Machine Directive 2006/42/CE.

2) complies with the requirements given in the:

- Directive 73/23/EC and 93/68/EC (Government Regulation No. 17/2003 Coll.)
- Directive 2004/108/EC (Government Regulation No. 616/2006 Coll.).

Defined by the EC directives for low-voltage installations 73/23/EEC and 93/68/EEC.

Defined by EC machinery standard 98/37/EEC Annex II A. Fans in air handling systems working with air from non-explosive buildings. These devices cannot be put into operation without first reading the assembly instructions and safety information.

The following harmonized standards are applied:

- EN 60 034-1 Rotating electrical machines; determination of nominal values and performance
- EN 60 204-1 Safety of machinery; Electrical equipment of machines; General requirements
- EN ISO 12100-1:2003 (ČSN EN ISO 12100-1:2004) Safety of machinery - Basic concepts, general principles for construction - Part 1: Basic terminology, methodology.
- EN ISO 12100-2:2003 (ČSN EN ISO 12100-2:2004) Safety of machinery - Basic concepts, general principles for construction - Part 2: Technical principles.
- EN 294:1993 Safety of machinery; Safe distances to avoid reaching dangerous places with the upper limbs.

- EN ISO 13857 Safety of machinery - Safe distances to avoid reaching dangerous areas
- ČSN EN 349 Safety of machinery. Smallest gaps to avoid compression of parts of the human body
- ČSN EN 614 Safety of machinery – Ergonomic design principles
- ČSN EN 953 Safety of machinery - Protective covers - General requirements for the design and production of fixed and movable protective covers.
- ČSN EN 1037 Safety of machinery - Prevention of unexpected start-up

The manufacturer undertakes to transmit all the papers, in response to a reasoned request of the competent national authorities, with relevant informations on this almost-machine and leaves intact his intellectual property rights. /

1) *splňuje požadavky dané Směrnicí o strojních zařízeních 2006/42/CE Evropského parlamentu a Rady ze dne 17. května 2006 týkající se strojního zařízení a o změně směrnice 95/16/ES (přepracované znění), a respektuje následující základní požadavky na bezpečnost a zabezpečení (příloha I):*

1.1.2 - 1.1.3 - 1.1.5 - 1.3.1. - 1.3.2 - 1.4.1 - 1.4.2.1 - 1.4.2.2 - 1.5.2 - 1.7.1 - 1.7.1.1 - 1.7.2 - 1.7.4.

Příslušná technická dokumentace je sestavena v souladu s přílohou VII B Směrnice o strojních zařízeních 2006/42/CE.

2) *splňuje požadavky dané směrnicemi:*

- *Směrnice 73/23/ES and 93/68/ES (nařízení vlády č. 17/2003 Sb.)*
- *Směrnice 2004/108/ES (nařízení vlády č. 616/2006 Sb.)*

Definované směrnicemi EC pro nízkonapěťové instalace 73/23/EEC a 93/68/EEC.

Definovaná normou EC o strojních zařízeních 98/37/EEC, Příloha II A. Ventilátory ve vzduchotechnických systémech pracujících se vzduchem z budov bez rizika výbuchu. Tato zařízení není možné uvést do provozu bez předchozího přečtení montážního návodu a bezpečnostních informací.

Uplatněny jsou následující harmonizované normy:

- *EN 60 034-1 Rotační elektrické stroje; stanovení jmenovitých hodnot a výkonu*
- *EN 60 204-1 Bezpečnost strojních zařízení; Elektrická zařízení strojů; Všeobecné požadavky*
- *EN ISO 12100-1:2003 (ČSN EN ISO 12100-1:2004) Bezpečnost strojních zařízení - Základní pojmy, všeobecné zásady pro konstrukci - Část 1: Základní terminologie, metodologie.*
- *EN ISO 12100-2:2003 (ČSN EN ISO 12100-2:2004) Bezpečnost strojních zařízení - Základní pojmy, všeobecné zásady pro konstrukci - Část 2: Technické zásady.*
- *EN 294:1993 Bezpečnost strojních zařízení; Bezpečné vzdálenosti k zabránění dosahu k nebezpečným místům horními končetinami.*
- *EN ISO 13857 Bezpečnost strojních zařízení - Bezpečné vzdálenosti k zamezení dosahu do nebezpečných prostor*
- *ČSN EN 349 Bezpečnost strojních zařízení. Nejmenší mezery k zamezení stlačení částí lidského těla*
- *ČSN EN 614 Bezpečnost strojních zařízení – Ergonomické zásady navrhování*
- *ČSN EN 953 Bezpečnost strojních zařízení - Ochranné kryty - Všeobecné požadavky pro konstrukci a výrobu pevných a pohyblivých ochranných krytů.*
- *ČSN EN 1037 Bezpečnost strojních zařízení - Zamezení neočekávanému spuštění*

Výrobce se zavazuje předat všechny dokumenty na základě odůvodněné žádosti příslušných vnitrostátních orgánů s příslušnými informacemi o tomto téměř stroji a ponechává nedotčena svá práva duševního vlastnictví.

Place, date / Místo, dne: Paskov, 1.3.2024

Legal representative / Zákonný zástupce společnosti:

Ing. Petr Adamík, CEO / Ing. Petr Adamík, jednatel společnosti

ADAMIK Company, s.r.o.
CZ-190 00 PRAHA 9, Pařížkova 910/9
IČ: 26845318

PRODUCT QUALITY AND COMPLETENESS CERTIFICATE

Filter unit:

- FT 616N A
- FT 625N A
- FT 631N A
- FT 627N A
- FT 637N A
- FT 647N A
- FT 638N A
- FT 650N A
- FT 662N A
-

- FT 716N A
- FT 725N A
- FT 731N A
- FT 727N A
- FT 737N A
- FT 747N A
- FT 738N A
- FT 750N A
- FT 762N A
-

Ventilator:

- VAN 828 3 kW
- VAN 831 4 kW
- VAN 831 7,5 kW
- VAN 835 9,2 kW
- VAN 840 11 kW
-

Serial number:	Checked by:	Date:
-----------------------	--------------------	--------------

Date of sale:	Delivered by:
----------------------	----------------------

Service / repair protocol:

The date of acceptance for repair:	Description:	Repaired by:

v.2026.05

ADAMIK Company, s.r.o.
Mitrovická 804, 739 21 Paskov
Czech Republic

VAT EU: CZ26845318
Tel.: +420 774 883 858
e-mail: info@adamikcompany.com

www.adamikcompany.com